



Cambridge Assessment
International Education

Coursework Handbook

Cambridge IGCSE[®] / Cambridge IGCSE[®] (9–1) Design & Technology 0445 / 0979

For examination from 2020



In order to help us develop the highest quality resources, we are undertaking a continuous programme of review, not only to measure the success of our resources but also to highlight areas for improvement and to identify new development needs.

We invite you to complete our survey by visiting the website below. Your comments on the quality and relevance of our resources are very important to us.

www.surveymonkey.co.uk/r/GL6Z NJB

Would you like to become a Cambridge International consultant and help us develop support materials?

Please follow the link below to register your interest.

www.cambridgeinternational.org/cambridge-for/teachers/teacherconsultants/

® IGCSE is a registered trademark

Copyright © UCLES 2018

Cambridge Assessment International Education is part of the Cambridge Assessment Group. Cambridge Assessment is the brand name of the University of Cambridge Local Examinations Syndicate (UCLES), which itself is a department of the University of Cambridge.

UCLES retains the copyright on all its publications. Registered Centres are permitted to copy material from this booklet for their own internal use. However, we cannot give permission to Centres to photocopy any material that is acknowledged to a third party, even for internal use within a Centre.

Contents

Introduction	4
Section 1: Suitable projects	5
1.1 Syllabus requirements	
1.2 Choosing a project	
1.3 Project outcomes	
1.4 Structure	
1.5 Content	
1.6 Use of ICT	
Section 2: Administering the project	34
2.1 General issues	
2.2 Health and safety	
2.3 Guidance to learners	
2.4 Internal assessment	
2.5 External moderation	
Section 3: Project assessment	36
3.1 General	
3.2 Project assessment criteria	

Introduction

This handbook has been devised to support the planning and delivery of the Cambridge IGCSE® and IGCSE® (9–1) Design & Technology (0445 / 0979) syllabus. It includes marked examples of candidates' work representing a good range of marks

It aims to improve your confidence in:

- developing effective and appropriate coursework projects
- applying the assessment criteria.

How to use this handbook

Read through the handbook, then **download** from the School Support Hub the sample projects A, B and C and compare your marks with those of the moderator. The moderator's comments on the marking are provided to offer insight into how to apply the mark scheme. We strongly recommend you view the projects on screen so you can expand the image sizes, but if you are going to print them, we suggest you do so at A3 size.

The project component of this qualification is marked by classroom teachers themselves. A sample of the marking from each centre is then sent to Cambridge International where it is moderated by our senior examiners to ensure accuracy and consistency across the entire cohort.

Additional support materials can be found on the [School Support Hub](#).

Section 1: Suitable projects

1.1 Syllabus requirements

The syllabus requires learners to take three components:

- compulsory component Paper 1: Product design
- compulsory component Paper 2: Project
- an optional component – learners take **one** paper chosen from the three below:
 - Paper 3: Resistant Materials
 - Paper 4: Systems and Control
 - Paper 5: Graphic Products

Each learner is required to undertake a personally identified project. They should produce this during the last two terms of the course. The timing means that your learners will be able to make full use of the knowledge acquired and the skills they have developed during their course. The project is likely to focus on the optional component your learners have taken, although there may be some overlap. For example, learners may wish to use electronics and / or mechanisms in their resistant materials project.

The work presented for assessment will typically be in the form of an A3 size design folder and a made product. Learners are encouraged to make full use of the range of ICT available to them for their project work. Freehand sketches, hand-drawn technical drawings and computer-aided design (CAD) generated drawings are acceptable for submission. The design folder must include sufficient photographs of the made product showing an overall view together with detailed views of parts or sections showing evidence to support the marks awarded for product realisation.

Photographs of particular construction details, or stages in the manufacturing process also help to confirm the quality of the product. The made product itself is **not** to be submitted for external assessment unless it is a 2-dimensional (2D) graphic product.

1.2 Choosing a project

Design & Technology is, above all, a practical subject which requires learners to produce made solutions to the design tasks undertaken. The product may or may not work successfully but learners should not be dissuaded from taking on challenging projects. All designers succeed and fail and most make many prototypes before they achieve a breakthrough.

Learners should be reassured that products which do not achieve the intended objectives can still be awarded high marks. In these cases there should be clear evidence in the design folder that the required process has been followed and that areas of failure have been identified with reasons given.

There is, however, a considerable difference between challenging and daunting. You will know the strengths and weaknesses of your learners and, as such, your initial guidance on the choice of project is vital.

The selection of appropriate projects may be approached in several ways. Some Centres give learners a free choice to identify their own design need from which they wish to work. They can discuss its suitability with you and modify as necessary. In others, the teacher may wish to give a group of learners a limited number of appropriate design tasks from which they choose one. Learner interest in the choice of project will help to maintain a motivated and determined approach to coursework.

There is no right or wrong method of approaching task selection, but the chosen method may reflect learners' levels of ability, or the nature of their previous experience of Design & Technology. It is inadvisable to allow learners to simply make what they want as this may lead to inappropriate project outcomes that do not reflect the required structure for assessment.

Whatever method is used, it is vital that learners take on tasks that can be completed in the time available and which allow them to respond to all sections of the design process in the assessment criteria. It is also important that learners are allowed only to take on projects that have a level of demand appropriate to their abilities.

Many successful projects start from a learners' own area of interest or hobby, or from a real design need found in their living environment. However, many extremely interesting and challenging tasks arise where a learner has investigated some social or community design need outside of their normal experience.

In order to access the full range of marks available, learners should avoid identifying the product outcome at the start of their project. What they should do is clearly identify the design need as this will encourage greater engagement with the design process. A statement such as, 'I am going to make a coffee table', is an example of where a learner has identified the project outcome, and this should be avoided. Similarly, learners should not take on a task that reflects a scientific or engineering approach as the resulting work may contain too much knowledge content and prevent them from producing and evaluating a meaningful, or working, product.

1.3 Project outcomes

Projects that focus on the Resistant Materials or Systems and Control options are usually straightforward. The main difference being that the Systems and Control projects will normally include consideration of aspects of electronics, mechanisms and structures. Learners should not be allowed to develop projects that focus solely on electronic circuits or mechanisms at the expense of the housing for the parts. A design process of the required nature for this assessment is only complete when the outcome is a usable and safe product or final prototype.

It is possible for the outcome to be a model, but this approach is only acceptable when the specification states clearly that a model will be produced and gives reasons for this. For example, a model of a bridge, for testing purposes. Many learners produce excellent architectural models which can be used to clearly show details to a client.

In the case of architectural design, the made product should be a well-constructed architectural 3D model. The model should be evaluated for its quality and effectiveness. Models are not appropriate as made products in other specialist options. For example, it is inappropriate to produce paper / card models as the final outcome for products that should be manufactured using resistant materials. Learners should create a product that can be properly tested and evaluated in the environment it is intended for.

If learners have chosen the Graphic Products option, their made product could be in 2D or 3D form. If it is 2D, the folder will contain all the preliminary design work and the made product. If the graphic product is 3D, the folder will contain all the preliminary design work and photographs of the made product – 3D made products are not to be submitted for moderation. It is essential that images which are part of a graphic product should be included in the folder and, if the scale is appropriate, developments / nets should be included.

1.4 Structure

There is no agreed or prescribed design process that has to be followed. Learners should be encouraged to structure their work in line with the assessment criteria contained in the syllabus. In this way, the guidance for learners will be clear and following this structure will mean that they will not miss out any of the evidence required for assessment. Having projects which follow similar structures will also make marking easier and where several teachers are involved should make the process consistent and reliable.

Cambridge International does not attempt to stipulate the number of pages required for the design folder as assessment is based on quality and not quantity. Learners should be encouraged to evidence this by making best use of time and space with appropriate and relevant information clearly presented on each page. They should avoid overly large fonts, large headings and unnecessary embellishment.

The marks available for each section of the design process should give some indication of the proportion of time which should be given to each. As already stated, various approaches and content are to be expected depending on the nature of the task. The following guidance is intended to cover the information which should be included as evidence for each section of the assessment criteria.

1.5 Content

The content of each project will reflect the needs and requirements of the design problem being addressed. The way the project is structured should mean that it covers all of the assessment criteria. This does not imply a rigid linear approach to designing and making. Learners are expected to carry out further research as they explore ideas and develop proposals. The following points offer guidance for each of the assessment headings as set out in the syllabus. In some cases, examples are given of the type of content that might be included. These must be seen as examples only, as there will be considerable variation in actual content depending on the design problem and outcome.

1.5.1 Identification and analysis of a need or opportunity leading to a design brief

Learners are required to state clearly a need or opportunity and to consider aspects of the design problem. This should include the context, situation and how these affect the intended user. A targeted questionnaire or interviews with possible client(s) can help learners to show that they have a good understanding of the needs of the potential user group. They would benefit from looking at the needs and expectations of the selected users. It may be useful for them to consider the type of environment in which the designed product will be used and highlight key issues.

Examples of questions that might be asked and answered include:

- Where does the problem exist?
- Whom does it affect? (Consider their age, gender or any particular problems, etc.)
- What are the consequences of the problem?
- What are the financial implications?
- Are there solutions already available?

This should be followed by a clear design brief stating what they are going to do.

IGCSE ARCHITECTURAL MODEL PROJECT

INTRODUCTION
On this page, I am going to start my Architectural Model Project. I'm going to make a transform to gather ideas for my architectural model. I will also write my design situation, find some evidence and create a questionnaire. After copying my results, I will write a design brief that will guide me through this project.

BRAINSTORM



DESIGN SITUATION
Students in China are under lots of stress. After constantly studying for school work and exams, they don't have anymore time or places left to have fun. In fact their stress levels are at 66%. This is a huge difference from the students in the USA as they are 24.3% lower. Life expectancies in China although not that low are also not the highest. For this reason a place to improve stress levels should be built. An aquatic centre would be a very good space where the young can relax and the old can combat the aging process.

QUESTIONNAIRE
The next thing I will do is a questionnaire, where I will ask around 40 people or more if they like my idea or not. I will also ask them if they like swimming or if a spot. Finally, ending with the question: Do you think there is a need of a new aquatic centre?

RESULTS

1. How stressed would you consider yourself from 1 to 5 (5 being the highest)?

1	15%
2	20%
3	30%
4	25%
5	10%

2. How much do you normally study a day?

0	5%
1	10%
2	15%
3	20%
4	25%
5	30%
6	15%
7	10%

3. How many times do you like to exercise a week?

0	15%
1	20%
2	30%
3	25%
4	10%
5	10%

4. Do you know how to swim?

Yes	15%
No	10%
Want to learn	75%

5. How far away is your nearest aquatic centre to your house by car?

0	5%
1	10%
2	15%
3	20%
4	25%
5	30%
6	15%
7	10%

6. Would you prefer to take:
Group • Private • Free

Group	20%
Private	30%
Free	50%

7. What do you normally like to do in your free time?

Listen to the music	15%
Read	20%
Watch TV	30%
Go to the gym	10%
Other	25%

8. Do you like to go swimming during the summer?

Yes	15%
No	10%
Only during the summer	75%

9. How good would you rate the aquatic centres in your city from 1 to 5 (5 being the best)?

1	15%
2	20%
3	30%
4	25%
5	10%

10. Do you think there is a need of a new aquatic centre?

Yes	15%
No	10%
Probably	75%

IDENTIFICATION OF A NEED

EVIDENCE
An international poll was taken in 2009 on senior high school students in China, Korea, Japan and USA. It was led by the China Youth and Children Research Center and corresponding organization abroad and proved that more than 90% of the Chinese students were under high stress (a 20% from the other three countries). Furthermore, it was also found out that this was caused by parents' expectations and peer competition. These levels are caused by China's national college entrance exam: one of the most important events in student's lives. This is because 10 million students are competing with each other for the highest scores and limited college places.

The can be a very big problem for those extraordinarily high stress levels can lead to feelings of despair, an elevated being of complaints with peers, and highlighted anxiety. So much that every year, Chinese newspapers were full with tragic tales of student suicides. It can also negatively affect the ability to concentrate. Although stress helps concentration for short periods of times but at the same time the brain starts fighting against itself.

As a consequence, some way to relax oneself is needed.

Swimming is a very good sport to improve one's fitness. In fact water is better than any other. As a result swimming is a much more effective way to tone muscles and increase cardio than any other workout on land. There is also a higher level of moisture present in the air of a swimming pool than in a gym. As a result, muscles are more hydrated and swimming can vastly improve asthma symptoms and help to increase your lung volume. Swimming is also really helpful to stretch out your whole body. In addition, it can avoid any risk of injuries during your workout, but only does it help you maintain a healthy weight but it also produces relaxation chemicals. Studies have, in fact, shown that swimming produces the same "relaxation response" as yoga and therefore decreases the stress levels of people.

Two maps are shown showing the number of aquatic centres in two different locations. The first map shows in Wenzhou and the other one in Wenzhou. The two are both cities but Wenzhou has 71 aquatic centres while Wenzhou has less than half of their number. There is clearly a need for a brand new, modern aquatic centre.

To further identify my problem, I will conduct a survey to the target user (students living in Wenzhou) regarding aquatic centres.

DESIGN BRIEF
I am going to design and make an architectural model of an aquatic centre. This is going to be situated in the city Wenzhou and should be big enough to fulfil all user's needs. Moreover, it should be located in an accessible zone in the city so that more citizens can easily reach it. The building will be designed for the general public, but mainly school students and elderly. My client will be the Chinese government (specifically the Wenzhou health section) and it will have the aim to reduce stress and increase fitness in the city. The building needs to be modern and in style and have good facilities that can cater user's needs. All of this will be created in the school workshop with the machinery and materials available.

CONCLUSION
On this page, I have identified a need for an aquatic centre in the city of Wenzhou. After doing a questionnaire and finding evidence, I have analyzed and realized that swimming is a good sport that can relax one's body and mind. Furthermore, due to not having any good, modern centres I can prove that this centre would be a good addition for the city. In the next page, I'm going to start researching an existing building to help me understand what makes them so successful or unsuccessful.

Example 1

This learner has presented a very well-structured sheet containing detailed identification of need with some reference to the user.

POINT OF SALE DISPLAY

to display promoted products that usually needed to be sold due to not commonly bought by shoppers or expiring date is near. In order to increase a business's profit or income. It is commonly placed near to the counter to attract customers.

Example:
Buy any 5pc for \$2.00.

WHAT IS THE MEANING OF COLLAPSIBLE
Refers to any item that is able to be folded down. Can be used more than once.

COMPANIES
usually offers great deals towards purchasing the promoted products.



MAINTAINLY MADE FROM HARD CARDBOARD

COMMON ITEM SOLD ON A DISPLAY
Snacks, Food, Beverages, Stationeries, office equipments

SOURCE OF FINDINGS FROM: OXFORD ENGLISH DICTIONARY

Example 2

This learner has used a different way to approach the analysis of the need for a point of sale display.

8 Cambridge IGCSE and Cambridge IGCSE (9–1) Design & Technology 0445 / 0979

SITUATION 2 COFFEE SHOP

Coffee shops are very popular nowadays. People always spend their leisure time at coffee shops buying some good coffee. But a coffee shop does not only serve and sell ready-made drinks. They also sell products of their own such as cakes or powdered coffee in packets (packet coffee).

WHY IS IT A PROBLEM?
By placing the products all over the cashier table may not attract customers on purchasing them.

Mainly occur whenever customers are paying at the cashier.

Customers might not realise there's products being sold next to the counter.

Affects both customers and the shop. Due to lack of attention on purchasing any of the products.

coffees are usually being sold in variety of flavours.

Example 3

This page shows evidence of the learner investigating a situation in which coffee shops sell and serve their products.

Mind map & Design Brief

Systems & Control

Mind Map

Design Brief

Since it takes too much time and effort to sort coins manually I will design and manufacture a device which will sort coins and keep them secure. This product will be aimed for banks since tellers are forced to sort coins manually, which hinders their job. It will sort coins of six different sizes into separate compartments. It is supposed to last for around 5 years or until new technology is developed. The product should not have harmful features like sharp edges or pointy parts. The manufacturing cost must be kept to the minimum in order to sell the product for a reasonable price. The impact the product will have on the environment must be controlled and, when possible, reduced by using as much environmentally friendly materials as possible. Finally, the manufacturing of the product should last 10 weeks.

Example 4

This learner has used a mind map approach to consider aspects for further investigation.

1.5.2 Research into the design brief resulting in a specification

In this section, learners are required to identify the requirements of the brief and to collect relevant information and other data. At this point, learners should not propose any solutions or even start to suggest ways of helping the situation. They should simply outline different aspects of the problem. Your learners might wish to consider existing products to help gather information.

Learners should avoid simply repeating extracts of information on materials, constructions, fittings and finishes from textbooks. Instead, they must produce evidence of having considered a range of ideas in order to access the marks available. For example, if they were attempting to create a product to store art / graphics equipment, the following might be considered, and relevant data collected:

- Where the product would be situated?
- Would there be a need to make it portable?
- How many items of art / graphic equipment would the product need to hold?
- What would be the size-range of the equipment?
- What form of storage would be most accessible (e.g. vertical or horizontal)?
- Could the storage have another function, e.g. hold paper while drawing / painting?

As well as researching the particular features of existing products and gathering information and data such as ergonomic or environmental factors, learners are also expected to collect information directly relating to the user and their needs for the product. This is often done through the use of interviews, surveys, letters, emails and internet research.

From the outcome of this research a list of specification requirements is produced. The points should be relevant to the particular problem and well justified. They should not be generic, such as: 'Must be safe'. However, safety issues might be covered in a statement such as: 'Knives or sharp pointed tools should be held securely so there is no chance of the user cutting themselves when using the product'.

Many learners include approximate cost in their specifications, but few include other quantitative requirements such as maximum and minimum dimensions and / or weight where appropriate.

The specification they produce should be used by learners when they are evaluating their ideas and when making a final evaluation of the made product. However, they should not simply use the specification like a checklist but should clearly evaluate the extent to which their proposals meet the specification. Learners may wish to add to their specification later as a result of exploring new ideas or developing their proposal.

IGCSE ARCHITECTURAL MODEL PROJECT

RESEARCH PLAN

INTRODUCTION
On this page, I will come up with the initial specifications for the final product. It will be broken down into different aspects and identifying the research needed. Finally, I will look at the possible sources for each element and categorize them into primary and secondary data.

RESEARCH REQUIRED

	What research?	Why do I need to research it?	How will I conduct the primary research?	How will I conduct the secondary research?
Function	I have to find out what components are needed in this type of building.	This research will allow me to design a building with all the necessary facilities.	I will conduct interviews and questionnaires to find out all the functions needed.	I will create a list of the facilities needed using the internet and other sources.
Aesthetics	I have to find out the form and shapes of existing buildings.	This research will help me gain inspiration for my own design.	I will take inspiration from nature. I will also visit and take pictures of existing buildings.	I will take inspiration from pictures of existing buildings I can find on the internet and in magazines.
Site	I have to find out an adequate location for the building.	This research will help me understand the size of my building and where it will be situated.	I will get first-hand data by measuring and taking pictures of the actual place.	I will use Google Maps to find the size of the space and take a picture of the exact view.
Existing buildings	I have to find out about some existing aquatic centres.	This research will allow me to compare them with each other and understand what makes them successful. I will also take some possible inspiration for my own building.	I will visit existing buildings in my city and take some photos.	I will search some other aquatic centres. I cannot visit, so on the internet.
Vital Sizes	I have to find out the actual size of the building. These include the doors, ceiling, length and width of the site.	This research will allow me to know how big I should design my building and give me the data I need when creating my model.	I will measure these sizes of doors, windows and rooms with a tape measure in my building.	I can use Google Maps to find out the length and width of the site. I can also find out some local sites from successful existing buildings.
Materials	I have to find out the materials I can use when manufacturing my model.	This research will help me know the uses of each material and which one is the best one I can use.	I will test out the materials provided in the school workshop to find out such of their advantages and disadvantages.	I will find out some more information on modelling materials in books, magazines and on the web.
Manufacturing	I have to find out which manufacturing processes I can use in the school workshop.	This research will let me understand the different equipment in the workshop and help me efficiently make my model.	I will practice using each machine and ask my teacher how they work.	I will learn more about the equipment through the internet and other sources.
User/Client	I have to find out the age, nationalities of my users. I also have to interview the client.	This research will help me understand the user's preferences and the requirements needed from the client.	I will be interviewing my target user group and taking pictures with them.	I will find some more statistics on the user group on the internet and in books. I will also find some more information on the client.

EXISTING PRODUCTS
Existing products are also very helpful for research on they can help you identify what makes them so successful and of the same time suggest to you what to avoid in our own design. In addition, the existing items and shapes can also help us find our own style.

PRIMARY RESEARCH
Primary research consists of a collection of data that is collected by the researcher first-hand. It is original and primary information recorded through various methods: the questionnaire, interviews, experiments and observations. This kind of research has both advantages and disadvantages. For example, it is very useful when finding out specific information. In addition, it allows the researcher to have greater control of the data. On the other hand, this type of research also has a few disadvantages. Firstly, it is quite expensive and takes longer to undertake than secondary research. Moreover, some data may also be out of reach to the researcher and even if it can be collected, sometimes it can become out of date.

SECONDARY RESEARCH
Secondary research consists of summarized and synthesized existing data. The difference with primary research is that this type of data has already been obtained and interpreted by the primary author. This information is normally a result of the primary data and can be found in different ways. These may include but are not limited to the internet, books, magazines and statistics. Like primary research, secondary research can be both advantageous and disadvantageous. It can be collected very fast and it won't be too expensive either. It can be collected for the same time and various can also be quite unreliable. Furthermore, it isn't always possible to find specific sections of a topic.

INTERNET
The internet is probably the most used source. In fact, it is used by almost everybody: children and adults, teenagers and adults. It is the easiest way for somebody to access information. It is both rapid and cheap. It is though flawed. If can be accessed for anybody and as a result it can sometimes be unreliable or false. Using it one has to be extra careful.

QUESTIONNAIRES
Questionnaires are one of the most effective ways to find information regarding the user's preferences. Just by talking with them we can easily understand what they are looking for in the building and their status as well. This can then help us in by influencing our design.

CONCLUSION
On this page, I have identified the design aspect I need to research for the design for my aquatic centre. I have also created a plan for my research which will be helpful for the development of my model. I have also written a quick explanation and a couple of examples of primary and secondary sources. In the following pages, I will continue my research more in detail for every aspect I have stated above.

INITIAL SPECIFICATIONS
The following points will be part of my initial specifications:

- The aquatic centre must be a place where students can relax their.
- The centre must contain all facilities needed for an aquatic centre.
- The building must also have a modern look and be a mix between curve and sharp edges.
- The building must be located in near the centre of research China.
- The shape of the building must be made with materials and look suitable in the school workshop.

BOOKS
Books are good sources for basic information. The knowledge you find in books is in fact endless. Thousand of books have been published and so it is easy anything we want to know can be found. However we can also be sure that the information can be reliable as it has been edited and checked through multiple times.

IMAGES + MAPS
Pictures and maps are good secondary sources. If we cannot go to the actual site, we can always search on Google Maps or on other websites. We can also use them to find out how they are worth. There is a reward word!

INTERVIEWS
Interviews are just as useful as surveys. These are completed with a smaller number of people, unlike questionnaires which are instead prepared for a larger amount of individuals. Normally a researcher interviews, reports and, in the end, the client. The questions are generally more specific and are answered more in detail. These are very helpful as they can supply us with data that the general public is not aware of.

Both sources have their own strengths and weaknesses like I have written earlier. This is why I will have a mixture of both kind of researches to be able to receive the best results.

Example 1

This learner has presented a detailed outline of research needed.

RESEARCH OUTLINE



THE PURPOSE OF THIS RESEARCH OUTLINE IS TO IDENTIFY THE SOURCES AND TYPES OF INFORMATION I NEED TO FIND OUT FOR A COLLAPSIBLE POS DISPLAY

SOURCE INCLUDE:

- Interview with people who uses pos displays.
- Observation of people who que up for the cashier.
- Internet websites on pos displays.

SOME INFORMATION I WILL NEED TO KNOW INCLUDE:

- Dimensions of pos displays.
- Places of pos displays.
- What people do with pos displays.
- How pos displays arrangement of items.
- Problems faced when using pos display.
- What existing solutions are around.
- Cost of such solution.
- Which material best fits the environment.

Example 2

This shows evidence of initial research planning.

DVD RACK STORAGE

ARRANGED AND CONNECTED HORIZONTALLY

WALL MOUNTED TYPE

ARRANGED OR CONSTRUCTED IN A ZIG-ZAG TYPE OF WAY.

*** AT SOME PART DIFFERENT TYPE OF METAL WILL BE INSERTED (SHAPE) WHICH IS THE**

WHICH IS THE METAL ROD AND SCREW CAP.

TO BE JOINED TO THE ITEM IN ORDER FOR IT TO BE MOUNTED ON THE WALL WITH THE HELP OF THE HOLES PROVIDED

IT CONSISTS OF PIECES OF PLASTIC PLATES (ABOUT 10 PLASTIC PLATES)

IT IS BASICALLY MADE FROM HARD PLASTIC FOR IT TO LAST LONGER AND HOLD UP WEIGHTS.

THE TWO SLOTS ALSO HAVE HOLES FOR CERTAIN

JOINED IN AN 'X' FORM.

WHERE BOTH HAVE TWO HOLES / SLOTS THAT ARE MEANT TO BE JOINED FOR IT TO FORM THE MAIN PIECE.

PROS Well spaced and divided for DVDs.

CONS Users take more time in the metal puzzles.

WE INSERT ANOTHER THE END OF BOTH AND COVERED THE END OF BOTH PART WITH THE SCREW CAP.

WHEN IT IS COLLAPSIBLE THE FINAL WILL LOOK LIKE THIS.

(FOR EACH) PLATES

INVESTIGATION OF EXISTING PRODUCTS

Example 3
Further focused research on DVD storage systems.

Systems & Control

Research for Components

In this section I will research 8 different components which could be applied in my project. I will address their function, whether its an input, process or output, practical use, cost, availability and their applications for my project.

This component is a toggle switch. The image on the right is its symbol and the one on the left is a photograph of the actual component. It is used as an input to cut and restore the flow of electricity in a circuit. When its lever is turned to one side the current starts flowing and is only broken when the lever is turned to the other side. This way, a circuit can be turned on when you want to and turned off when you want to, so you can control quantity of electricity it uses. It can be used in a circuit that has to be turned on to work so that it is not on the whole time and it doesn't waste electricity. It has a very low cost and it is readily available. In my project I plan to include a circuit which has a 4-digit password. For this circuit to work, it has to be powered when the password is typed, but the password can be typed whenever the user wants to. Because of this, if the circuit did not have a toggle switch it would stay on all the time, wasting a energy. This is harmful to the environment and it is expensive. This is why I will include a toggle switch for the customer to decide when to turn the circuit on or off.

This component is called the 555 timer. It is used to delay pulses of electricity a given amount of time. When it receives energy it takes a signal that it should discharge that energy in the time set by the user. It is a process, since it happens between the input (a switch) and the output (the outcome the pulse it releases will trigger). It is used when you want an output to happen after some time, say, because you want it to happen exactly after or at the same time of another output. It is an expensive component because, as you can see in the component symbol, it has many parts to it which have different functions. Because its specific use, it is not as readily available as other components. I could use this in my product if I wanted the product to auto lock when it is closed. I could set a time for it to do so.

The components above is an LED (light emitting diode). As its name indicates, it emits light. You can see that its symbol is similar to that of a diode but it has arrows indicating it is an output and that light is coming through. It works with polarities; when one side gets powered the electricity travels up one of the wires and goes through the gap between them inside the translucent dome. The colour of the light is decided by the colour of the translucent dome. It can be used either to produce light and therefore illuminate something or catch people's attention or it can be used to indicate a process is going on. It is very common to have an LED showing whether the circuit is on or off. Because of its simple elements (wire and translucent plastic) its cost is very low and because of this and its many potential uses it is readily available. I will use an LED to indicate whether the circuit is on or off, but I also could use another one to show when the drawers are not locked.

The component above this description is the solenoid. It is a really useful component and one vital for the development of my project. After much consideration about the subject I realized a solenoid is the best solution for an electronic lock for my project, since servos move in a direction which is not useful for more than one drawer and other options are not as readily available (even though solenoids are scarce). When it received a charge, it stretches one of its parts because of an electromagnet and when that charge is dropped it flexes again, making it an output. This can be inverted by switching polarities. Because of its very practical use, it is most often used in car doors and in moving train rails. Since it has many expensive materials (like the electromagnet) it is expensive. I will use it in my product, together with other non-electronic components to create a lock which can lock six different drawers.

Example 4
Research on specific components which will probably be used in the product.

Similar Products On The Market

In this section I will analyze products which are relevant to my design brief to get acquainted with the features my product should have. This way I can design a unique product which does not have a direct rival. I will do this by addressing the features, costs, materials, functions and power supplies of the analyzed products.



This product is a coin sorter that works with a spinning handle. It works by having a metal disc that spins when the handle is turned and has a slot close to its circumference by which the coins reach to the separate containers. Like mine, this product is used to sort coins without any effort from the sorter. This product does not have to be electrically powered and looks very durable. It sorts coins to a very large scale, even though I don't aim to do that since that would make my product too big. This product is also not very aesthetically pleasing since the mechanism is exposed. The mechanism of this product is made of metal which looks like aluminum or stainless steel while the stand and the four trays are made of plastic. This product is undoubtedly out of my possible price range at \$950.00. It costs this much because the coin sorting is done at a large scale and because the product does not have many competitors. It is made to sort coins just like mine but works in a different way. In conclusion, the only feature I could use from this are the plastic boxes used to sort the coins.

This product is a coin sorter similar to my idea. The sorting in this product is achieved by using the power of gravitational pull to move the different coins through different sized tracks, which finally end up in piles at the bottom of the sorter. The sorting system involving gravity is a good sorting method. This product also has a low production cost. However, as this mechanism is also exposed, therefore its aesthetics drop. It is entirely made of plastic, except for the metal bar at the back to support it. It costs \$99.00, which is closer to my product than the last product but is still more expensive than what I plan my product to cost. This product almost completely answers my design brief, but it does not keep the coins safe and it does not look elegant. In conclusion, I could use the sorting system used by this product for mine.



This is an electronic coin sorter, though it has roughly the same end and purpose as my product. It works by feeding the coins into the hole in the upper part when the device is on. Its electronic part is in charge of the sorting and of the wrapping of the coins. This product is aesthetically pleasing since the circuit is not exposed and has an attractive casing. One the other hand, this casing looks brittle and slightly cheap. It is made of plastic which looks like acrylic. It costs \$25.00, which makes it relatively low cost. This product responds to my design brief slightly since it aims to sort coins but does it in a very different way than mine. Overall, I believe that this product, even though it sorts different sized coins, does not have the features my product needs to be successful to achieve its aim.



This product is an electronic plastic safe box. It has buttons with numbers from 0 to 9 to enter a 4 digit password and open the box. It is relevant to my product because I plan to include a 4 digit password to open the compartments. The passwords system is a good feature since it is simple and effective, however, this particular product looks cheap since it is made entirely of plastic and can be broken very easily (therefore it can't store objects of value). It costs \$19.99 so it has an accessible price. This product answers my design brief in the lock aspect. In conclusion, I will use the four digit password feature this box has to lock the coin compartments of my product.



This product, just like mine, is a manual coin sorter. It has 8 removable compartments placed each on top of the other. Each of these compartments has many holes in its bottom. The highest compartment has the biggest holes and the lowest has the smallest. Only the coins which are supposed to be in each compartment will not fit in each hole, so if you shake it the coins will get sorted. It is completely manual and does not need maintenance or greasing (since it does not have mechanisms). On the other hand, it looks easy to break and it is tedious to open it for each compartment when you want to take the coins out. It is also not very visually attractive. Since this sorter is entirely made of a low-cost-looking plastic - such as polythene - its price should be around \$10. This sorts coins and has a low cost therefore partly answers my design brief but does it in a different way than my product. In conclusion, I could include this sorting system to my product since it's efficient but I won't because I already have a sorting system and



This is an electronic coin sorter, somehow similar to the third analyzed product. Apart from being a coin sorter it is relevant to my project since I am planning to sell my product to banks and this is a very professional, bank-teller-looking product. It is good because it can sort coins quickly and up to 8 different coins. It also looks appropriate for a bank and can be painted with a bank logo's colours. However, this product is too big and sorts coins to an overly large scale. It is made from metal and plastic in what looks like a durable build. It is the most expensive product reviewed at \$1,300, which is too expensive for my budget. This answers my design brief partly since it has the bank-ish look I want to achieve with my product. In conclusion, I will try to make my product look somehow like this one by not having an exposed circuit/mechanism and by making it look professional.

Conclusion:
I have found that coin sorters can be both mechanical and electronic, that coin sorters can achieve a bank like appearance without stopping to fulfill its function and that electronic safe boxes use convenient circuits for a project of mine's nature. Therefore, I have decided I will use a mechanism similar to that of the second analyzed product. I will make my product look professional like the sixth analyzed product and I will use a four digit password similar to that of the fourth analyzed product. This is because having these features my project will answer my design brief the best, which says that the project should be kept low cost (first decision), it appeals to banks (second decision) and finally should have an electronic password lock (third decision).

Example 5

The learner has researched similar, existing products to identify positive and negative features that will help them to formulate a specification and inform their design.

Specifications

This page contains the specifications that my research shows are optimal for my product. In the final design, all of this specifications should be met.

Function	The product must be able to sort a range of coins. The product must have a locking system which only opens when a code is entered. Must tell you when each drawer is full.
Client	The product must be aimed at bank tellers who fall in the age group of 20 to 60 years old. The product must not appeal to one gender more than the other.
Safety	The product must not be harmful to people who work in a hurry. The product therefore must not have any sharp edges or pointy parts which could hurt your hands.
Size	Should be a suitable size to fit on a desk and must not be too big to obstruct site for a sitting teller.
Cost	The product costs around \$20 to manufacture, therefore, the product must not cost more than \$60 dollars.
Aesthetics	The product must have a plain, professional look since it has to appeal to bank tellers in a working atmosphere.
Environment	The product must be appropriate for a working environment, more specifically, a bank. The product must also be eco-friendly and its effect on the environment must be as reduced as possible.
Ergonomics	The product must have drawers which can be comfortably pulled by an adult hand.
Finish	The prototype must have a professional, varnished, wooden finish but must have enough space in the casing to be painted with a bank's logo or colours
Scale of Production	The product must be produced in mass, therefore the design must be kept simple enough to do this.

Commentary:

In this section I have produced a list of specifications which my product must meet in order to satisfy my market's expectations and to be as close as possible to what my research proved to be optimal. I will use this specifications during the designing process to ensure they are met.

The table to the left are the specifications.

I have also produced a table by which to judge each design idea. It uses a number system from 1 to 5, 1 meaning not met the specification and 5 meaning completely met the specification. Numbers 2, 3 and 4 are for any place in between.

Function	
Client	
Safety	
Size	
Cost	
Aesthetics	
Environment	
Ergonomics	
Finish	
Scale of Production	

Example 6

This is an initial specification showing how the learner would use a table to judge design ideas. Their commentary explains their reasoning.

IGCSE Design and Technology Specifications

Introduction
On this page I will use ACCESSFMQP to create design specifications to aid my design. ACCESSFMQP links in with my analysis questions.

Field	Essential	Desirable	Reason
Aesthetics	1. Should be mainly silver (50.01% ^c)	2. It could have a metallic finish.	Most clients like the colour silver the most when asked which they prefer between silver, black and red.
Cost	3. It should cost less than \$100.00 to produce and be sold at a profit.	4. It would be great if it costs less than \$50.00 to make and sells for \$100.00 or more.	The people aren't able to spend too much on a bike stand and won't buy it if it's expensive.
Consumer	5. The consumer is anyone who cycles and wants to repair their own bike. One consideration could be making it weigh less than 8 kilograms so that people could lift it quite easily.	6. Consumers could personalise their bike stand by adding unique decals.	If consumers could personalise their stand they would most likely buy my product and not others where they can't personalise the stand.
Environment	7. The materials should be recyclable. The materials should be able to withstand the outdoor conditions found in Africa.	8. The materials could be widely recyclable and once the stand has served its purpose for around half a decade the parts could be melted and used for something else.	Many clients will be very environmentally aware in the future and will want to buy a product that could be used for something else.
Safety	9. The repair stand shouldn't fall over easily.	10. There should be no sharp edges that could harm the user.	A stand with sharp edges that falls over easily is a disaster waiting to happen.
Size/Structure	11. The bike should not be out of reach when put on the repair stand.	12. The repair stand could adjust height and thus be accommodating to each and every customer of any height.	My product will be even more optimised for the user if this works.
Function	13. Repair stand should be able to hold one bike of any frame size.	14. The stand could also hold tools while supporting a bike.	The product will be multi-functional and most people don't want something that can only do one thing. A watch, for example, is now expected to not just tell the time but have other abilities too.
Materials	15. Should be made from metals as they appear to be the most suitable group of materials for the stand from preliminary analysis.	16. Materials should be lightweight while still maintaining its qualities.	A repair stand that is portable needs to be lightweight yet strong, otherwise clients won't buy it.
Quality	17. The product should last for at least 3 years.	18. The product lasts for 10 years.	People will love the idea of a lifetime warranty and that the stand is guaranteed to last so long that it is more likely to be lost than broken.
Portability	19. The product should be able to fit in the standard SUV and be easy to carry.	20. The product is quick to assemble and disassemble. Quick being less than 10 minutes.	The very origins of this product is around the ability for it to be easy to transport without a fuss.

Summary
I have used ACCESSFMQP on this page to make my specifications. These specifications have made me realise that I will need to smooth the edges of the final product to make the product safe. It shouldn't fall over easily either otherwise it won't be safe. I have also learnt that considering the consumer will vastly improve my design. For example, having adjustable height means that any consumer of any height can use the product. Also, the product should last for at least 3 years. After it has passed its useful lifespan, most parts should be recyclable. The stand should be made of metal. This metal could have a shiny blue finish. Finally, it would be cheaper than most existing products if it sells for \$100.00.

Example 7

This learner has given a well-justified specification.

A summary can be helpful to pick out areas to focus design thinking on.

Specifications

Specifications	Detail	Evaluation
Target Audience	This piece of furniture is aimed at adults, mostly young adults, as they are usually cheap and easy to assemble. It is also aimed at both genders, boys and girls. Both genders from this age would want cheap and easy to assemble furniture. This piece of furniture will have a simple design and will have non-gendering colours. At the same time it will be eye-catching, as well as not too much or too little detail.	This will be proven by asking the target audience to evaluate the finished product. They will be asked questions on how much they like the finished product, as well as if they think it is suitable for their age and gender.
Anthropometrics	The furniture will be a suitable size for the target audience. It will not be too small for the average young adult, nor too big. The size will not cause the furniture to become too heavy or unusable for the young adults. The target audience will be able to carry it without difficulty, and will be able to use it.	The folding chair will be tested by observing the young adults using the furniture and carrying it. I will analyse if they had any trouble using it.
Safety	The furniture will have no sharp edges, but it will have smooth edges with no splints for the adults to be harmed with when carrying it. The different pieces will be correctly attached, so that nothing can fall off and hurt the target user.	To test the furniture against this design specification, I will take a safety test before letting the target audience use it. I will make sure nothing is able to fall off or break.
Material	The furniture will be suitable for the target audience to use. It will likely be made of cheap but durable and light materials.	The furniture will be proven against this design specification by evaluating the durability of the furniture. I will also test if it is lightweight and cheap.
Aesthetics	The furniture will be eye-catching and will be in trend so that many young adults will want to own the furniture. It will have bright colours and look relatively modern, as many young adults like to have modern-looking furniture in their homes.	To make sure that this design specification is met, I will ask the adults how trendy the furniture is in their opinion and if they would consider buying it.
Mass Production	I am only planning on making one prototype, but if it were to be mass produced I would make the furniture out of easily produced and manufactured materials (e.g., plastic). I would also consider the cost of the materials, in order to make profit.	To evaluate this design specification I would research similar pieces of furniture and find out how they were mass produced in factories.
Function	My product is designed for young adults living in small spaces. The furniture will be easy to use and fold. It has to be able to fold properly so that the target audience can use it. The folding furniture needs to save space.	Study on the way of folding furniture work and evaluate how efficient my folding furniture is.
Quality Standards	The quality of the furniture should be good, it would allow the adult to use it on a regular basis. E.g., if a piece of furniture falls apart the first 30 days, the user will need to buy a new piece of furniture due to the low quality.	Tests could be carried out to make sure that the choice of the material we use to produce the folding furniture would be most suitable in.
Time Scales	When producing my products, I will need to have a lot of time to produce the folding furniture so that I am satisfied with it. I will need to make sure that every little detail is perfect and ensure that it looks good and professional.	The time taken for the making of the furniture can be simply estimated on how much work I will have to put in my folding furniture in a lesson depending on how sophisticated my furniture will be and also depending on the mechanism of it.
Where will it be used?	The furniture will be used indoors as it is more likely for young adults to only have a very small area to live in, not including any outdoor area.	I will test this design specification by evaluating the furniture against other indoor furniture to see if it has any similarities.
Maintenance	The furniture will be easy to maintain as it will be made of a durable material, as that makes the furniture easier to fold. The furniture will likely have to be cleaned quite often as it is aimed towards younger adults using the furniture every day.	I will test this by having different damaging impacts happen to the furniture and seeing if the furniture has become ruined.
Ergonomics	The furniture needs to be comfortable for the adult to use. It needs to be the right size for them to use it properly. It can't be too small that it isn't usable. The furniture needs to contain smooth and no sharp edges. In addition, the furniture will need to be light enough for young adults to be able to carry the furniture comfortably.	To make sure that this specification is met, I will have adults use the furniture and test how easy it is to fold.

Example 8

This learner has given a very detailed and well-justified specification.

1.5.3 Generation and exploration of design ideas

Learners have the opportunity to show their creativity and imagination in this section by exploring and proposing design ideas.

There is no preferred method of presenting drawings, but ideas should be clear to the observer. In most cases this will be through freehand sketching with sensible use of colour and / or shading as required. The use of more formal drawing techniques can have a constraining effect.

For the highest marks learners need to offer a wide range of appropriate solutions showing imaginative interpretation. They should not focus on one or two concepts but record any ideas they have.

Drawings need to be annotated so that they relate to the specification and any research that has been carried out in the previous section of the folder. Although there is no requirement to develop a chosen idea at this stage, learners are advised to include notes on possible materials, constructions, the range of forms considered and other details so that the reader can see how ideas have emerged.

A successful set of design sheets should enable someone who has not seen the work before to have a clear understanding of why the project has developed the way it has. Learners should identify good ideas as they proceed so that these can be brought together at the development stage.

In the case where learners are using CAD to generate ideas, it is advisable for them to also use pencil or pen sketches so that they can explore their initial ideas quickly in order to produce a wider range of possible solutions.

Many learners present their work with a good integration of annotated sketched ideas and design possibilities with simple models. This helps to show the natural progression of design and development.

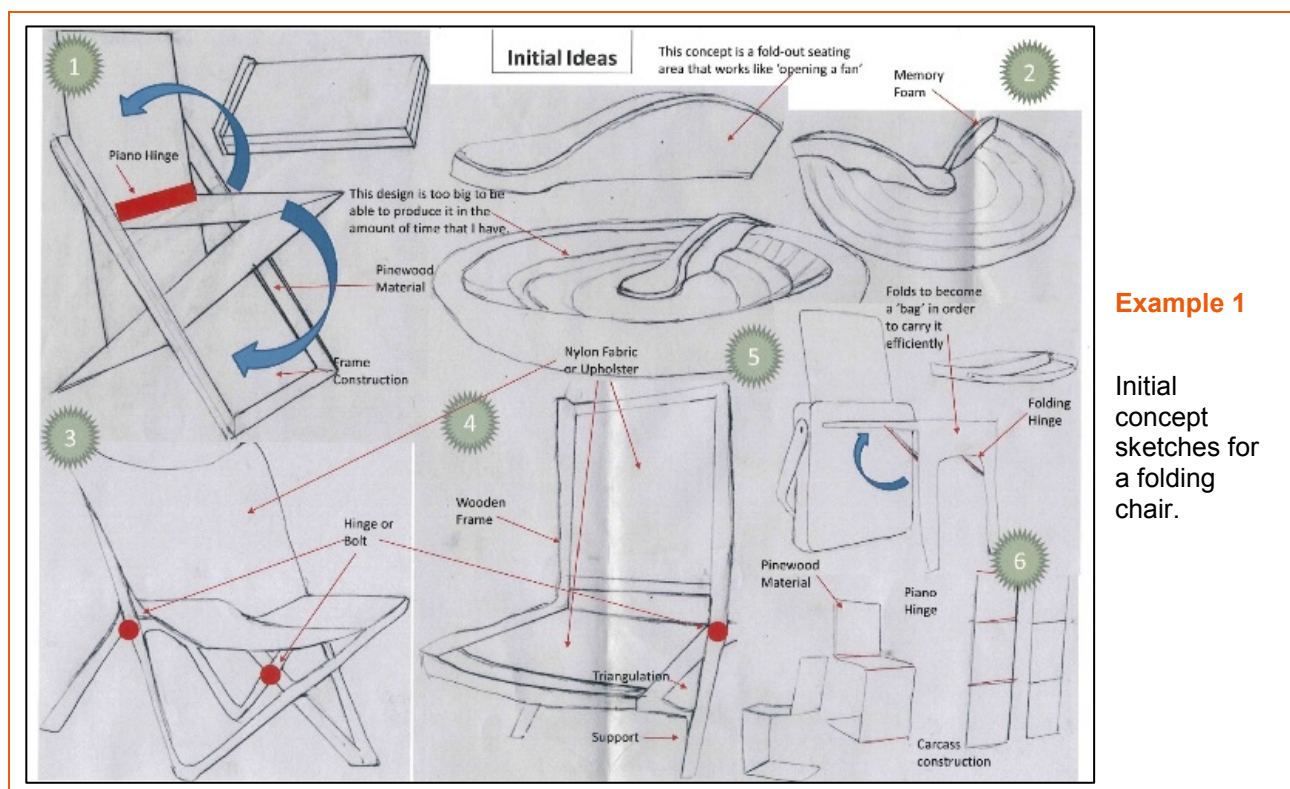

1.5.4 Development of proposed solution

Learners need to bring together relevant ideas from the previous section and make decisions about form, materials, constructions, production methods, finishes and all other details relating to the final proposal. There should be some indication of the alternatives that have been considered and reasons for their decisions.

For the highest marks learners need to show that they have carried out appropriate modelling and trialling with regard to most of the points considered. This should take the form of 2D and / or 3D modelling to test simple mechanisms, functions, evaluating overall shape and form, or testing construction techniques and possible materials.

In all cases, learners must focus on the ideas being developed and not just present general information extracted from textbooks. For example, a long list of woods, metals and plastics with their qualities and uses serves no purpose if it does not relate and refer to the ideas being considered.

Learners following a Graphic Products option must not forget to consider all aspects of semi-resistant materials, joining methods, rendering techniques and reproduction methods, as appropriate.

Learners following a Systems and Control option must not focus simply on developing electronic circuits, for example, but consider all aspects of the final design so that it is developed into a complete product.

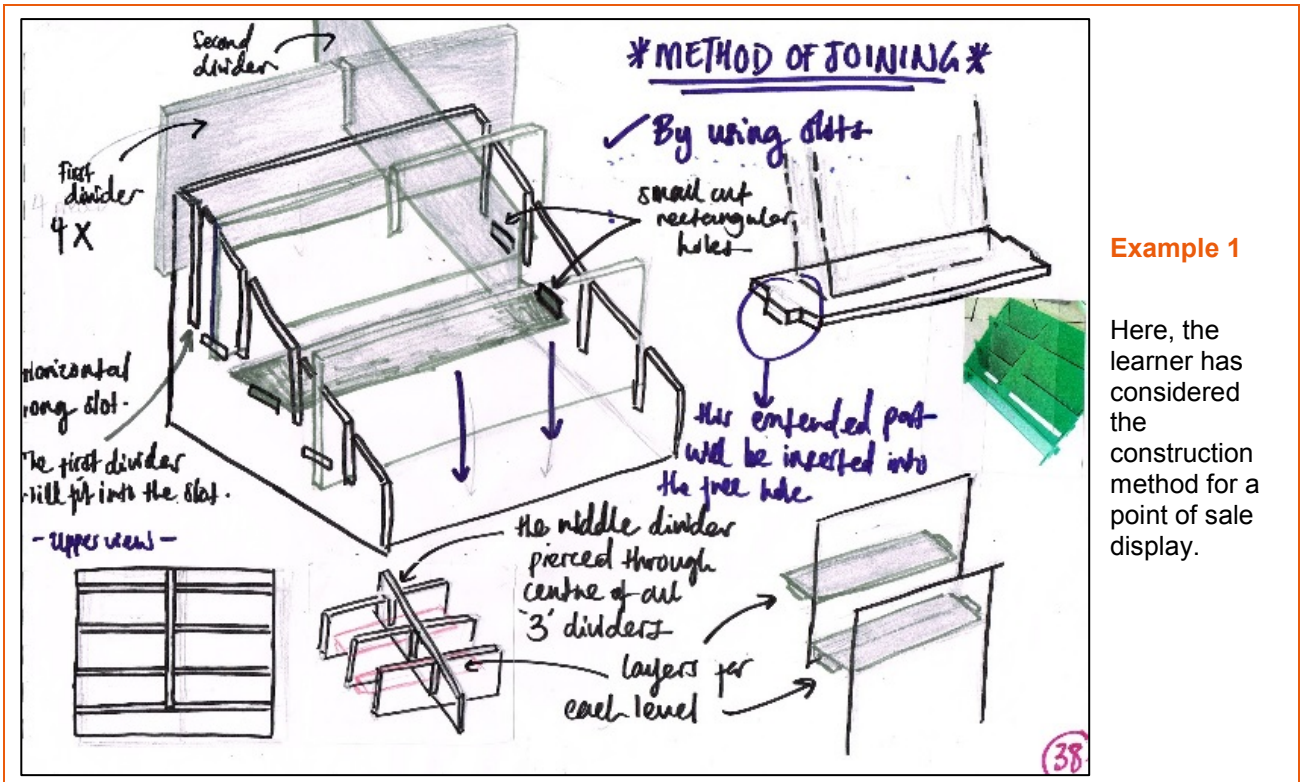

Example 1

Here, the learner has considered the construction method for a point of sale display.

IMPROVED DESIGN OF MY MODEL!

How all parts originally look:

← storage of eye shadow palettes
* each slots may store up to 2 posh palettes

Consist of 6 divided slots

1st vertical dividers

Horizontal layer dividers

Will be inserted into the slots at the sides

Layered according to the structure of stairs

Additional Info: logos or design is from Engraving.

The first front space divider is where the main logo of the palette brand.

Edges

36

Example 2

Effective use of simple models to help to decide on the best method of production.

IGCSE ARCHITECTURAL MODEL PROJECT

INTRODUCTION
Although I have already produced a final idea for my Aquatic Centre, an alternative pattern is needed as well. On this page, I will create many different ideas to choose from.

DEVELOPMENT SKETCHES

FRONT VIEW

SHAPE NOW FLATTER THEREFORE MORE APPROPRIATE FOR ITS PURPOSE

NEXT TO MAKE IT MORE CREATIVE AND ORIGINAL A PATTERN HAS TO BE FIRST CREATED THEN CHOSEN

BUILDING 3D PRINTED AND PATTERN LASER CUT

DIFFERENT TRANSPARENT ACRYLIC TRIANGLE

CONCLUSION
On this page I have sketched various different patterns. In addition, I have also numbered them, later on, I will run a questionnaire which will help me choose two designs. In the next pages, I will continue my development section. I will use different materials and manufacturing methods, available in the school workshop to create preliminary rough models.

TOP VIEW

Example 3

Developing further ideas from initial concepts. This sheet focuses on aesthetic features.

IGCSE ARCHITECTURAL MODEL PROJECT

After having finished my models, I took out pieces that could be used to decorate the outside. These included trees, users, and stones. I have also laser cut more blue acrylic rectangles and a white tear-drop shape with rectangular grock that represent the outdoor pools.

Then, using solvent and a paintbrush, I glued the small acrylic block people onto the orange floors or the black facilities.

After having glued down all the people inside the center, I positioned the models into the pattern previously drawn. Then using a hot glue gun I created an X with the glue and firmly placed the orange floor onto a wooden board.

I positioned my orange floors and then gently placed the white model over it. After checking that everything was suitable, I glued the white PLA walls down onto the wooden board with a hot glue gun.

FINAL PRODUCT

After having finished making my model Aquatic Centre, I positioned it in front of a plain sky blue wallpaper. I then started taking lots of pictures of the whole model from different point of views to clearly show all aspects of the design and manufactured product.

PRODUCT REALIZATION

CONCLUSION

In the three pages of Section 4, I have described my product realization through photographs and short commentary. I have finally concluded, by showing various angles of my final model with an all sky blue background.

In the next section, I will evaluate the final model to the specification and take an interview with a possible user.

STONE PATH

PEOPLE

TREES

Example 4

Here, design possibilities are evaluated against the specification with clear reasoning shown about subsequent decisions.

Development Circuit

Systems & Control

The software Yenkka proved to have limitations for my circuit. There was no component for a keypad, however, this is the way Yenkka represented it. This worked fine in the 2D circuit but didn't do so well in the 3D model (as you can see). However, since these models are just a way of representing the circuit they serve their purpose and are good enough for this stage of my development. I also have avoided the use of the relay because it would complicate the 3D model and thus hinder its clearness.

This problem also happened for the PCB tracking because of the same reasons, which is a small drawback to my development process but is not so determining as to prevent me from communicating what the PCB would really look like.

PCB tracking

Example 5

Developing a circuit using software to check suitability for the functions required and PCB production.

Systems & Control

Development Circuit

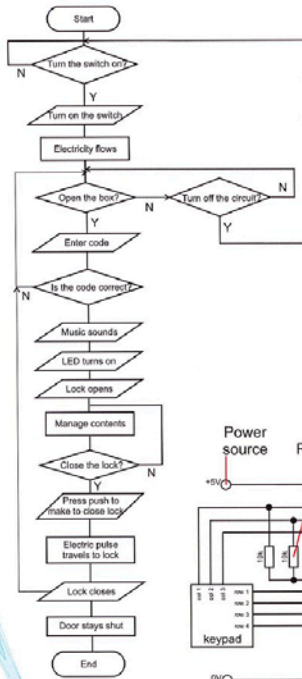

How does the circuit work?

- The circuit works in the following way: when the correct code is entered at the key pad, an LED flashes, a sound is emitted different to the sound produced when any key is pressed and finally the lock opens.

Why is this the chosen circuit?

- This is the chosen circuit because it meets my specifications the best; it has a solenoid lock, it is powered by a power plug and it uses a 4-digit pass-code. This way the user will be able to keep his/her contents inside the box safe from theft or from other people disorganizing it. This method is also more practical than having a key because the pass-code does not need to be carried and can only be typed by the user and the people the user decides to give the power to, since they have to know the code.

Manufacturing method:

- After the circuit is done in Yenka, it must be printed to was is called the mask of the PCB. After that, we prepare the photo resist board and put the mask on top of it so that it is then exposed to UV lighting. The PCB-to-be is placed on the etching tank of the tank developer and then in the rinsing tank (to get rid of the toxic waste). After confirming that the PCB is in good quality the holes are drilled the PCB is completed.

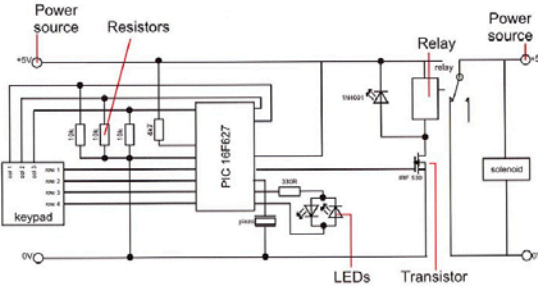

Pictorial view

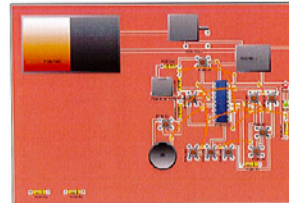

PCB track

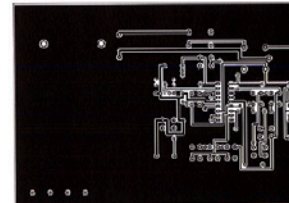

PCB track with components

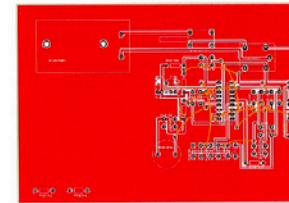

Example 6

Development of a circuit leading to a proposed solution.

1.5.5 Planning for production

Learners need to provide all the information that would allow a skilled person to produce the final, developed design idea. This should include an effective order for the full sequence of operations, working drawings and a list of the materials required.

Working drawings need not necessarily be orthographic projections but they must be fully dimensioned and provide all the information required for the complete final product.

The sequence of operations does not require learners to give detailed information on basic procedures such as marking out, cutting, simple shaping, etc., but they should include information on the more complex operations especially if these are new to them.

You must remind learners that they have ownership of their coursework – including the manufacture of the product. Any external help outside of usual teacher / technical assistance must be acknowledged, and the marks adjusted accordingly.

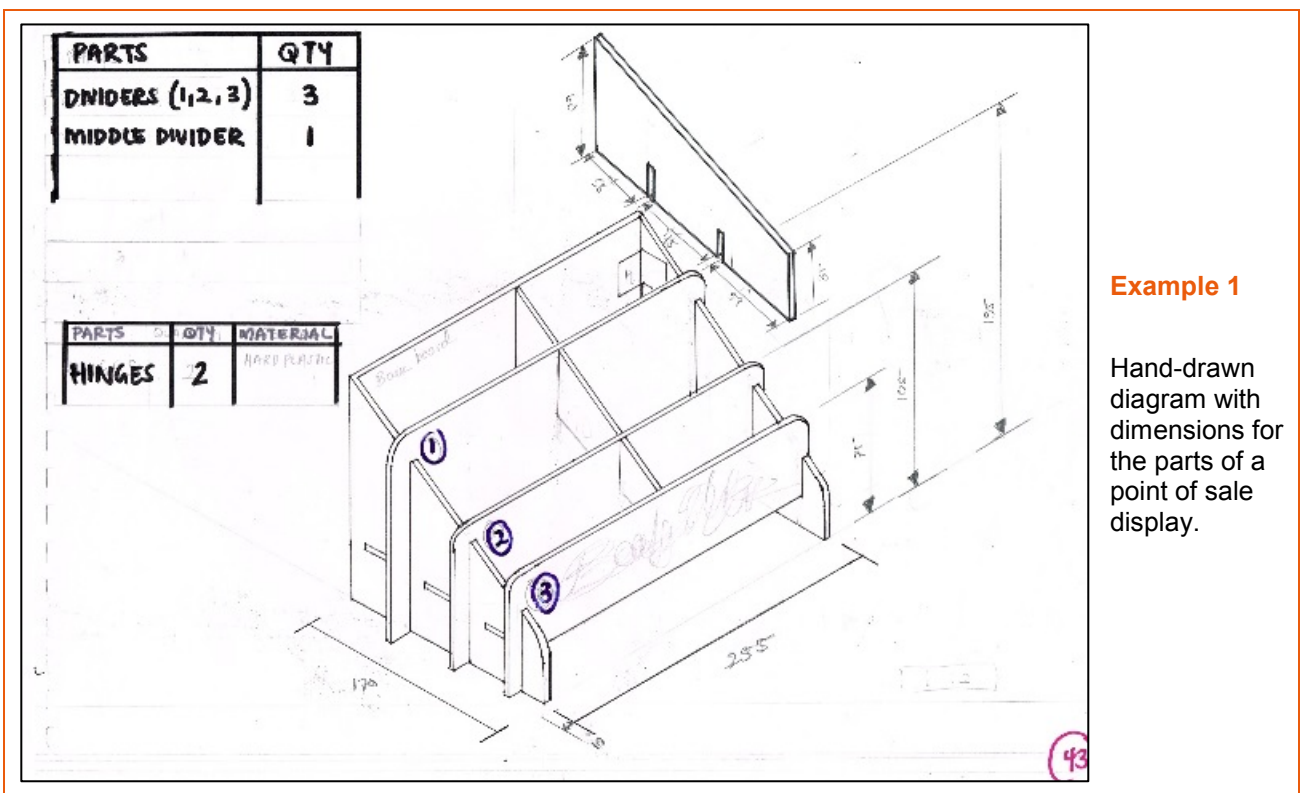

Example 1

Hand-drawn diagram with dimensions for the parts of a point of sale display.

IGCSE Design and Technology **Final Design Parts List and Manufacture Plan**

Introduction
On this page I will make notes and drawings regarding the parts required for the bike stand.

Part #	Part Name	Quantity	Further Notes
1	Base Side Bar	2	Grind down outer edges slightly to avoid sharp corners.
2	Central Rear Bar	1	Grind down outer edges slightly to avoid sharp corners.
3	Anchor Pins	1	N/A
4	Spacer Tubes	1	Round the outer edges.
5	Slip Tubes	2	When slipping onto spacers, apply grease.
6	Feet	4	N/A
7	Nuts and Bolts	4	N/A
8	Washers	4	N/A
9	Washers	4	N/A
10	Rotary Mechanism	1	Apply cover grease to the central hole when assembling the final product.
11	Plugs	4	N/A
12	Stabiliser Pin	1	Apply cover grease when inserting into the rotary mechanism.
13	Rotary Anchor	1	N/A
14	Outer Tube	2	Use thick aluminium tubing.
15	Rubber Inners	4	N/A
16	Nuts and Bolts	4	N/A
17	Spacers	2	Apply lubrication when inserting into slip tubes.

All parts are made of aluminium unless specified otherwise

Summary
On this page I have drawn and annotated the parts required for the bike stand. I did this because it will help me to make the parts properly.

Example 2

Sub-assembly drawing of component parts.

IGCSE ARCHITECTURAL MODEL PROJECT **FINAL GRAPHICS**

INTRODUCTION
On this page I will display the isometric views of my model's design once again as the previous model was unable to be made. Just like the other version, I will also add the size of the length, width and height of the model in millimetres.

CONCLUSION
I have finally finished designing a suitable design and shown in different views. Next, I will display on a full scale a larger, clearer version of my laser cut pieces and its size.

Example 3

CAD drawing of final proposal for an architectural model.

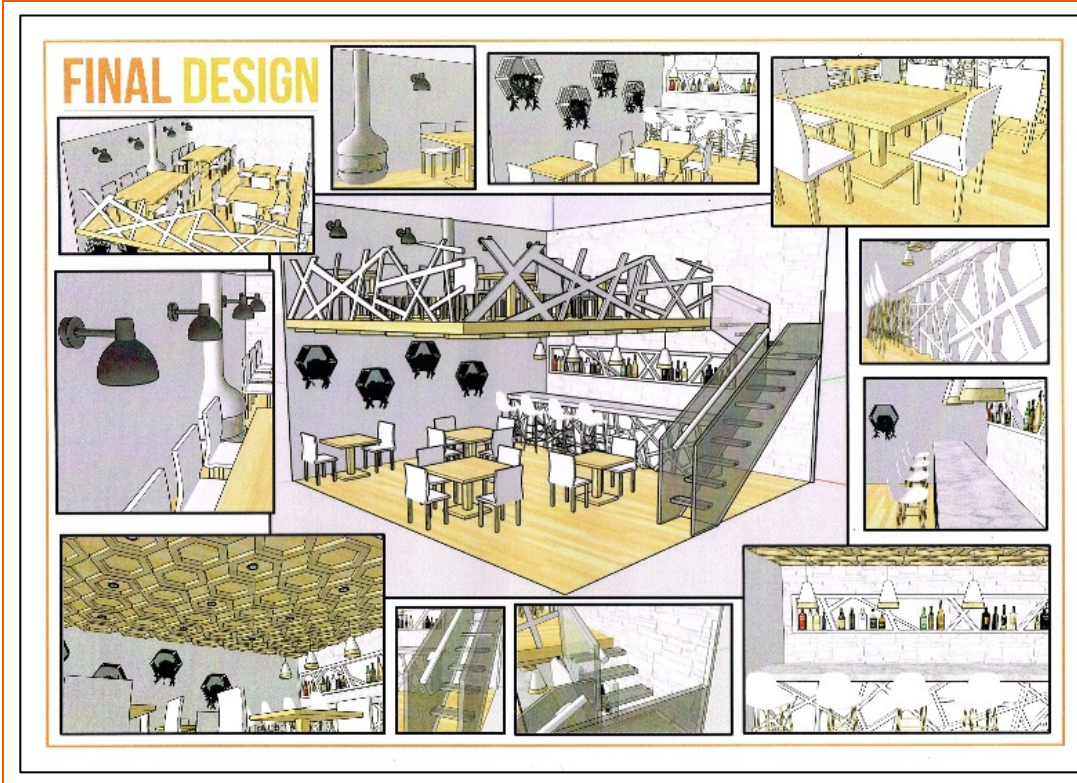

Example 4

CAD drawings of final proposal interior layout of an architectural model.

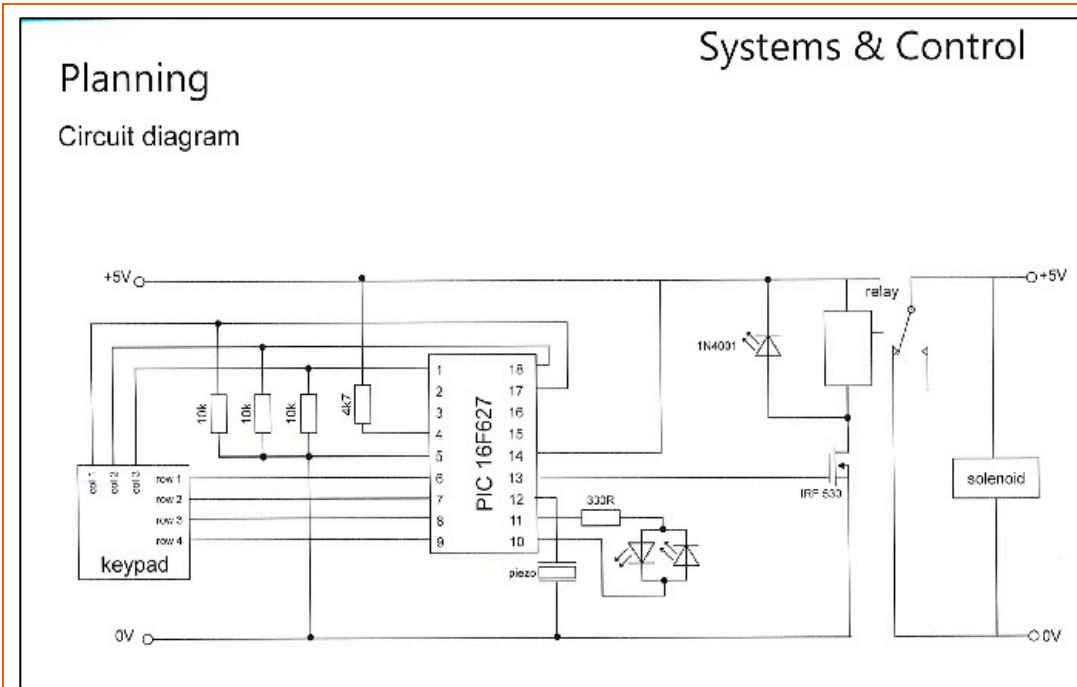

Example 5

Final circuit diagram for product. Details of the product casing were also included in the project.

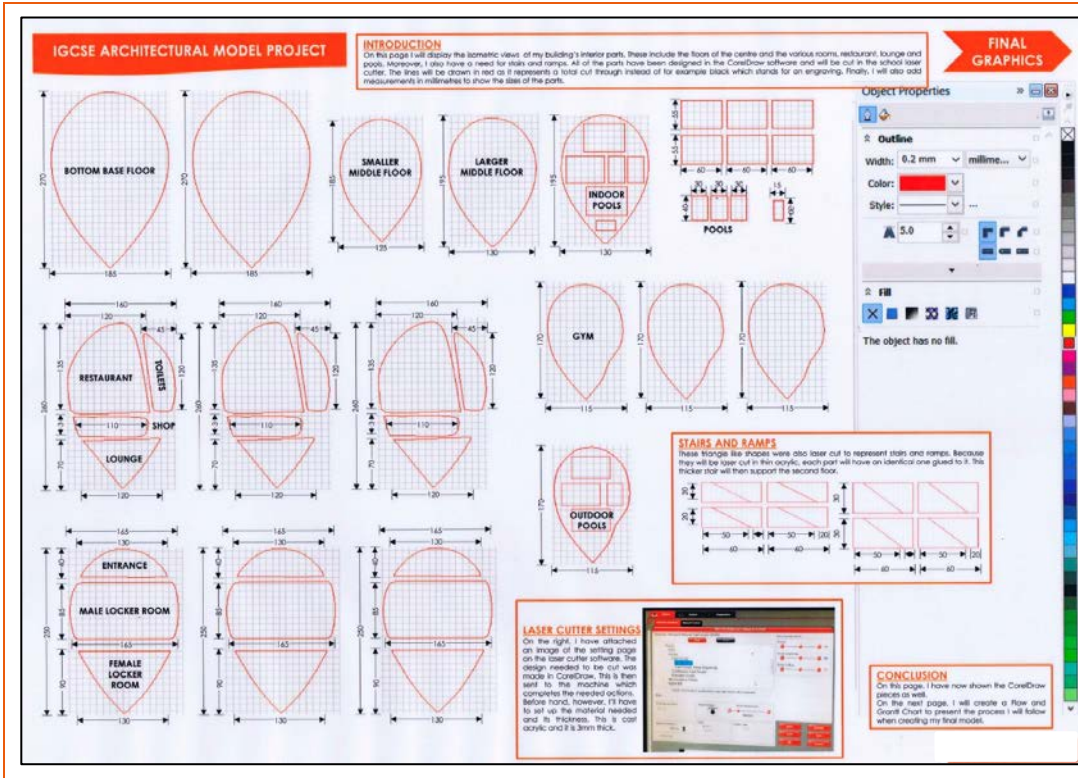

Example 6

Detailed CAD drawings of building with parts prepared to be laser cut.

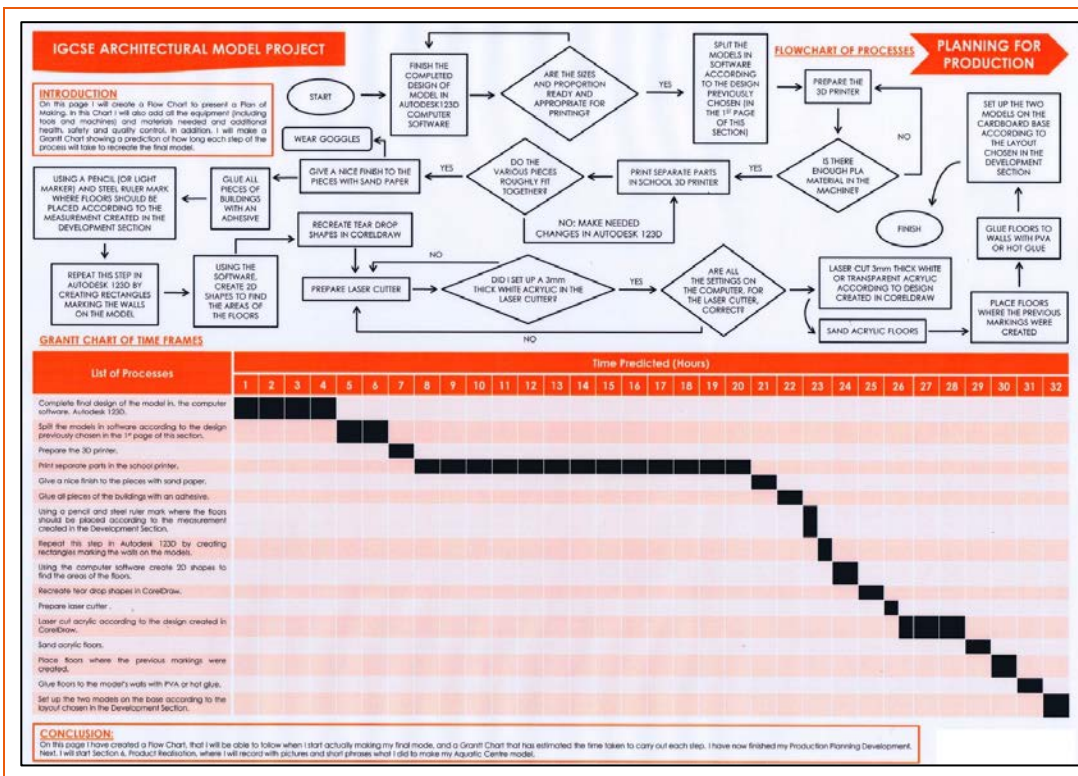

Example 7

Detailed plan of manufacturing operations listed with breakdown of approximate times for each stage.

1.5.6 Product realisation

This is the opportunity for learners to show how they can manipulate materials to produce usable high-quality products. Clearly the product will be based on the drawings for the final developed design idea but if modifications need to be made as the manufacture progresses, these can be referred to in the final section of the folder.

Learners should be encouraged to design products that give them the opportunity to demonstrate a range of constructions and techniques. However, in the marking of this section you will need to balance the standard achieved and the complexity of the construction being attempted.

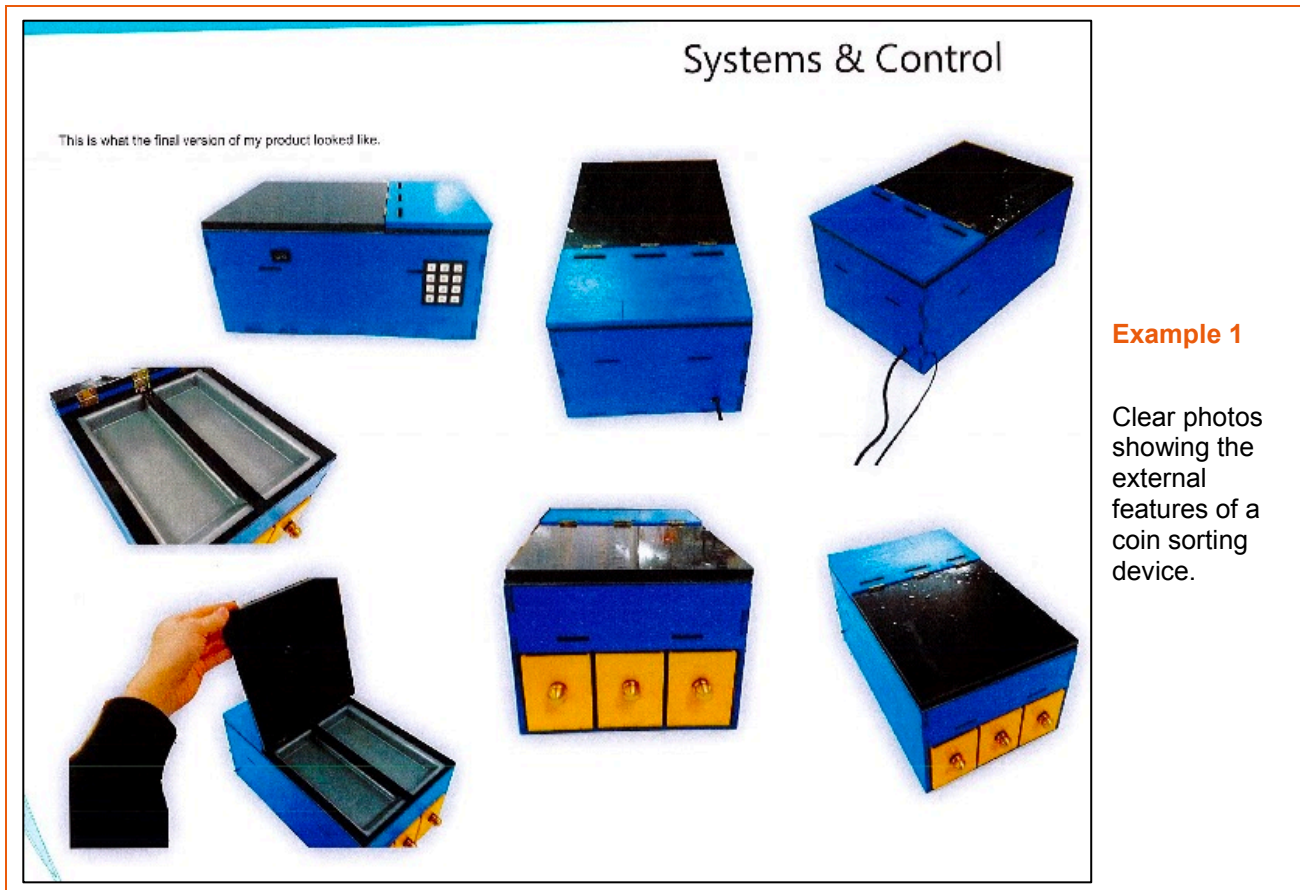





IGCSE ARCHITECTURAL MODEL PROJECT

INTRODUCTION

On this page, I will add the model's various views in a logical order to show more clearly the building's outer and interior designs and its size and proportions.

FINAL PRODUCT

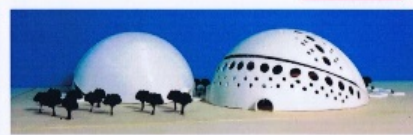
CONCLUSION

On the next page, I will show one image of the model. The picture will take up the whole side to emphasize each part of the building.

Example 2

Evidence of final outcomes of an architectural model.

Final Design

Below are pictures I took myself of my final product by itself and also while I was testing it with various items.





Example 3

Different views of a desk tidy.

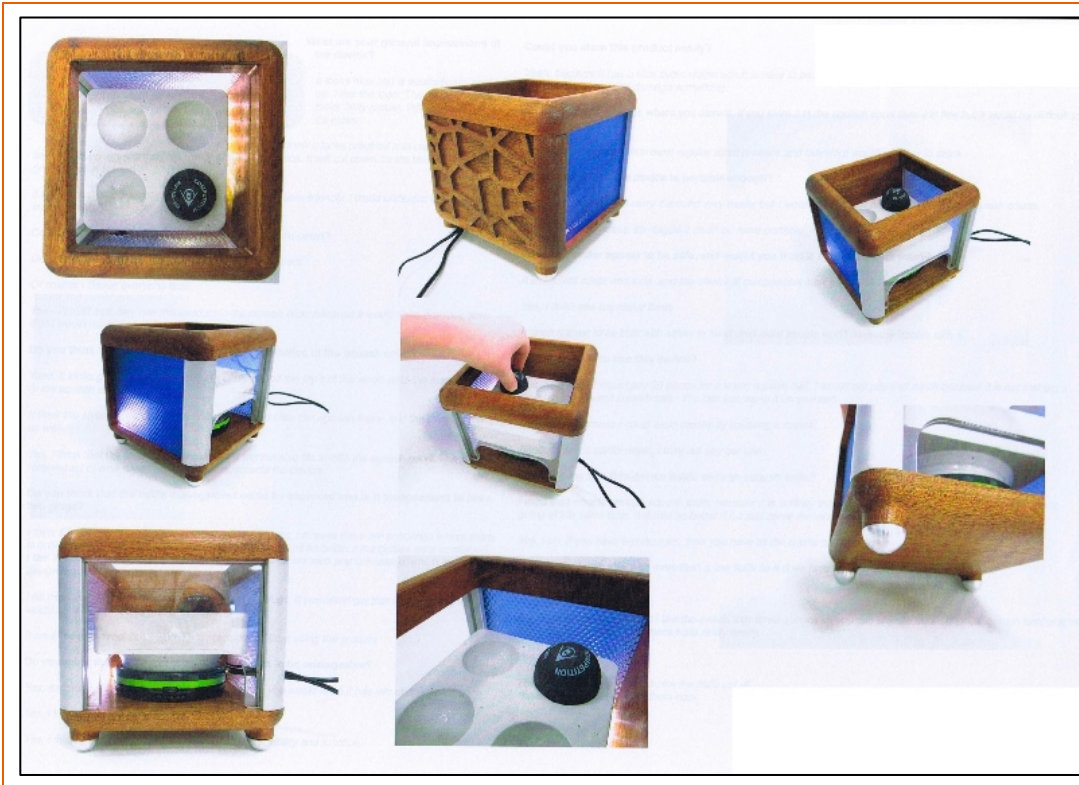

Example 4

Views of a squash ball heater.

1.5.7 Testing and evaluation

It is important that learners test their made product in the environment for which it was designed. This can be evidenced by information and records from the testing and through photographs with comment.

Learners must also refer to the design specification during the testing process and record comments as appropriate. A list of the specification points with ticks or crosses serves little purpose unless these are commented on in some way.

Where the learner has worked closely with a client it is very helpful for them to be involved in the testing and evaluation stage. Their feedback is very important to the learner and will help them to formulate a final evaluation and draw meaningful conclusions for improvements or modifications. Questionnaires can serve some purpose but comments from them need to be collated and referenced to the specification and the product.

The evaluation should include the identification of strengths and weaknesses and proposals for modifications. Modifications should ideally be demonstrated in the form of sketches and notes. Learners should avoid the temptation to use this section to comment on the project overall and describe the problems they had with materials, construction, etc. Evaluation must be of the product in use, as it performs against the specification.

IGCSE ARCHITECTURAL MODEL PROJECT

INTRODUCTION
On this page I will continue my evaluation by conducting a questionnaire to a wider group of users to find their thoughts and feelings on the model. I will also create a questionnaire to find the overall response from a broader audience. Next, I will also add some sketches to show how I could improve the design or manufacturing method if I had to repeat the project. Furthermore, I will make a general comment on problems faced, successes/areas one and what I have learnt.

IMPROVEMENTS TO PRODUCT & MANUFACTURING
One evident problem I encountered when making my final model was the actual design of the Aquatic Centre. This was because the 3D printer machine in school was unable to create the pattern I had imagined. As a result, I had to change the design of the building. However, no matter what I did, the printer repeatedly refused to create what I desired. So, to keep a hint of the original look, I decided to replace the small rectangles with circles. In the end, the model came out quite nicely but I think I could have created a better outer appearance if I only concentrated on a circular design instead of leaving the original one.

If there were a next time, to avoid wasting time continuously remaking the model and checking one of the time if a design could be printed, I would make some small test products, I would do this by creating smaller practice models by printing sections of the building with the various designs. After collecting the result data, I would proceed from there to actually making the actual size design on Autodesk 123D. This would not only be efficient time wise but also material wise as less PLA would end up being wasted.

However, the change in design did not affect my flow chart on the processes were left the same. The only difference from the original plan was that the final step I wish the model design on the computer software I look more than the 3D printer. The model was that I instead took double the time as two designs were created in the end.

Another obstacle I encountered which was also noticed by the client and mentioned during our conference, was the lighting and the staircase, in both corridors and by hand, I had planned out the position and size of each facility and from there I laser cut each section in acrylic. To connect the two floors in each building I also laser cut some staircase. These were three separate shaped acrylics glued onto each other. Everything seemed fine until I placed out everything to see how it would be placed. Then, I noticed that the sign were quite thick and occupied more space than I had anticipated. The building with the soccer room and the swimming pool, don't have any radiocast changes as I was able to position everything so that it would fit. But for the one with the restaurant, lounge, shop and gym it was a bit harder as the spaces were quite tight in the first place. So I had to get rid of the shop.

Below I have attached a sketch of how I would place the whole building if I repeated them.

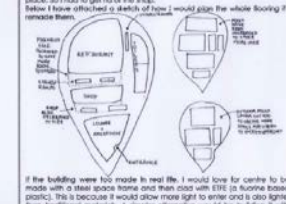

If the building were too much in real life, I would love for centre to be made with a steel frame and then clad with ERG 18 flame board panels. This is because it would show more light to enter and it also lighter than traditional materials. A similar alternative would be building it with concrete and then coating over a metal plate.

TESTING WITH THE USER

INTERVIEW
To test my model with the user, I directed an interview with Pavla, she is a student who has previously lived in Wenzhou (the city where the building would be located) and has experienced Chinese school life. As a result, she is able to give the point of view needed. I have asked a couple of questions and she has answered truthfully and also coincided with a first personal review. These questions were the same as the ones asked to be completed in the last page but by involving a younger student, I am able to see a wider range of views.



QUESTIONNAIRE
After the interview with my user, I also created a questionnaire that could be answered by a larger group of users. From the results I was able to see the more general and common view on the appearance and usefulness of the centre.

1. Do you like the building's aesthetic?

Yes	85%
No	15%
2. Are there enough facilities inside the centre to cater all users?

Yes	80%
No	20%
3. Do you think the building would be easy to navigate or a well lit site?

Yes	80%
No	20%
4. Would you really be able to reach the site of the building?

Yes	85%
No	15%
5. Would you come to the Aquatic Centre?

Yes	85%
No	15%

During my interview, my user made a suggestion on the building's design. As a result, I decided to ask if the audience agreed with her, or not, in the survey as well.

4. Do you think the model would look better with an increase of windows?

Yes	85%
No	15%

EVALUATION

TESTING WITH THE CLIENT
Other than testing my product with my user, I also interviewed my client. As stated previously in the Research Section, my client is the Head of Government of Wenzhou Municipality (The local Chinese branch), Mr. Zhang Gang, the mayor, however was unavailable. So, I decided to call a government worker Mr. Zhang Guo (in a government office) to help.

The conversation was taken over a Skype call and I have attached his translated comments below:

"Good morning. First of all, thank you for having me here. I'm so happy to meet you. I'm glad to see your model for us."

I must say, the building's design is very beautiful. From the pictures you have sent me and what I'm currently seeing in video, the centre seems quite elegant and has a modern design. The proportions of the whole centre with the location seem to be right as well.

I have noticed that there were multiple pools inside, and outdoor pools are present as well. As a result, I see that there is enough room for all potential users to use the pool without the concern of waiting. In addition, I like the fact that you have added a gym on the second floor of the other building as well. I think having such a vast area is necessary for ones who'd like to workout before or after work.

However, the shop you have previously mentioned is not great. First, there was a problem when designing each floor. Due to the fact, that the staircase occupied more space than I expected in the model, I had to take the shop out. In real life, I would obviously add that if and to create enough space for it. I would decrease the area of the restaurant and the shops. Well, start worry as it isn't really a huge problem. I'm sure it'll be able to fit the scale we constructed another facility one way.

So, to conclude, I must congratulate you. The model seems to have completed almost if not all product specifications. It has a unique look, is able to execute its function and all in the location desired. Moreover, the attention to detail was excellent as well. About, corridors and ceilings have been made quite carefully and anyone would be able to easily enter and exit the building. I represent the Mayor Mr. Zhang Gang and the government when saying that the Aquatic Centre is great and would be perfectly suitable in our city of Wenzhou.

OVERALL CONCLUSION
On the page I have finished my evaluation and my Architectural Model Project. I have taken two interviews and a questionnaire to satisfy client and users' opinions. Moreover, I have also written about problems faced and what I modifications I'd make to avoid them a real time.

Overall, believe the project was quite successful. Although, I have encountered a couple of problems during the manufacturing process, the Aquatic Centre model came out quite nicely. By adding the extra details the model looked like a building we could find in real life.

This project also taught me many things. I have learnt to meet all objectives and take things one step at a time. Instead of getting a large scale model immediately for example, it's always better to make a smaller prototype to check that everything's correct. The coursework also taught me the feeling of putting lots of effort and hard work into something and the satisfaction experienced having concluded it.



group of users invited to see and review model

Example 1

Well-presented sheet showing evidence of client's involvement with the testing and evaluation of the final proposal.

Cambridge IGCSE and Cambridge IGCSE (9–1) Design & Technology 0445 / 0979

29

CONSUMER EVALUATION – INTERVIEW

I conducted an interview with a friend for a more detailed response, to follow up the questions in my survey.

QUESTIONS AND ANSWERS:

Many people in the survey believed that the bar was too tall in comparison to the tables. Do you think the bar should be made smaller or kept the same height?

I must agree with them. Because the bar is so tall, the bar stools are also quite tall, making them more difficult to get into. I would lower the height primarily to make it easier for customers to get into and out of the stools. Other than that, the bar is very nice. The marble looks elegant and the façade's design emphasises the geometric theme.

In another question, people said there was not enough lighting in areas of the restaurant. Where would you suggest more lighting fixtures put in?

The bar is well lit due to the pendant lighting, and the second floor with the wall lights. I would suggest adding lighting fixtures near the steps on the stairs, as it may also be a safety precaution at night. Adding more basic ceiling lights would also contribute to the overall lighting on both floors of the restaurant.

What do you think of the two different table designs?

Separately, the two tables are very good. One is simple and sturdy, while the other contributes more to the theme, with a better shape. However, together, they are questionable together, as it seems messy having only one or two tables with one design and the rest as another design.

If one of the tables were to be removed, which should be removed and why?

When the simpler tables are placed by themselves in the restaurant, they are subtle and neat, with chairs easily placed on all sides of the table. When the table with the geometric design is placed by itself in the restaurant, it looks too busy, with too many geometric patterns in the restaurant. Unlike the other table, chairs can't be placed on the ends, which is another negative. So, when weighing up the pros and cons of each table, the simpler tables are better overall. However, some important features from it could be transferred to the other table.

In the survey, the majority also said that the walls were too plain, lacking interest. Do you agree, and if so, where should more attraction be added?

Yet again, I agree with the majority. Behind the bar is fine, as there is a shelf which is very necessary. The wall to the left of the shelf is also sufficient, as the plants make the restaurant look fresher, and the white walls somehow also seem whiter. They also add a pop of green, so I would suggest adding more plants around the restaurant. In my opinion, the issue is with the second floor. Other than lighting, there is nothing on the walls, making them look empty. The wall to the right of the wall lights is the most plain, so I think that a form of art or another feature should be placed there.

Do you think that there should be more tables and chairs place in any empty spaces?

I think there are enough tables and chairs, specifically on the first floor. Although, usually when I walk into a restaurant there is a reception desk of some kind, placed near the door. It adds to the visual appeal of the restaurant and essentially makes it easy for us, as the customer, to be taken to our table and so forth. To improve, I would add a desk near where the front door of the restaurant would be.

ANALYSIS:

This interview is very helpful, giving me more specific comments that will aid me in making modifications. The first question tells me that the bar is in definite need of resizing, however the design and choice of materials for it are clearly a strength of my restaurant. I have decided to add lighting to the base of each step, as this, like said in the interview, also can help improve the safety of my restaurant. It is also best that the table with the geometric design is abandoned, as one of my biggest worries while designing and making this restaurant has been putting too much emphasis on the theme. However, the curved corners of the table edge are an important safety feature, so I feel that it is vital that I use this in the original design. When changing the table legs while I was developing my table, I said it was a necessary change as the central stand was not strong and sturdy enough for the large rectangular table to withstand large amounts of weight. I did not want this to remain an issue with the six-seating table, so I decided that while the four and two seating tables have only one stand, the six-seating table will have two stands to address the problem. When looking back at past restaurant experiences, I, like the interviewee, also recall entering the restaurant and immediately going to a desk of some sort. To increase efficiency of the restaurant, I believe I should add a desk, with a similar design to my bar. This means that the consistency through the restaurant is not broken. The mood and colour scheme are also areas of strength, with the fireplace proving to be more of a significant feature than I had thought it would be. When doing my lighting research, I originally thought that white lights would accompany by restaurant, but now I feel it would be too bright. Overall, the interview was successful, and will help me make improvements to exceed customer satisfaction.

Example 2

Good use of questionnaires to evaluate the final outcome.

3

EVALUATION

My design turned out well. All parts had worked properly. Although there are slightly changes or differences. Compared to the models before. I beautified my design by ensuring it looks clean and neat. Which I had managed to spray paint it in black colour. I chose black because, my products are white in colour!

BLACK & WHITE are good colour combinations.

It holds up the product very well and the structure is also stable. No faulty of standing upwards.

Although it looks neat and clear, there are actually covered with scratches and hand stains. (certain parts that are commonly in touchers with items or human hand)

Example 3

Brief, personal evaluation identifying some strengths and weaknesses of the product.

COMPARISON of my Design Specification & Artifact



- | | |
|---|---|
| <ul style="list-style-type: none"> ✓ HOLDS UP PRODUCTS ACCURATELY. ✓ COLOURS NOT AGAINST PALETTE'S. ✓ PRESENCE OF BRAND LOGO. ✓ HAND FRIENDLY. "NO SHARP ENDS" ✓ STABILISED DESIGN. ✓ PRESENCE OF DIVIDERS. ✓ MARKETABLE YET AFFORDABLE. | <ul style="list-style-type: none"> - IT IS PROVEN WHEN I TESTED THE ARTIFACT. - YES, I CHOSE BLACK BECAUSE OF THE GOOD COMBINATION WITH WHITE. - ACCOMPLISHED! - NOT QUIET, ONLY CERTAIN PARTS. - HIGHLY AGREED & FOLLOWED. - DIVIDERS ARE PRESENT. - MY DISPLAY IS VERY AESTHETIC. I DIDNT COST MUCH ON DEVELOPING MY DESIGN. |
|---|---|

Example 4

A brief check against specification can lead to a more detailed evaluation.

Some improvements and modifications are outlined. This could lead on to a more detailed description using annotated sketches.

(49)

FUTURE IMPROVEMENT

If I were to improve my design, I would choose another option of colouring. Due to the material, it is smooth and soft therefore the spray paint may scratch up and loosen. To be safer, I would just look for an original black colour of the strawboard. (as it is available in varies of colours)

In terms of joining method, I would improve the sharpness of the slots. Therefore, it is more stiff and fixed. I will also increase the number of self design hinges. So that the whole structure of my design has a longer life expectancy. Changing the shape of my design may also be helpful. I would change it into a taller structure kind of design. Because I chose my design to be a table mounted type of display. Therefore it will be more eye catching in customer's view. My product would be even better or efficient if it were to be place in an opposite direction. Which also means, having to show off the reading (front) of the product. In other words, place it horizontally rather than vertically. I wont be able to change the position freely because the dimension of the space provided for the product is already fixed. It wont fit for horizontal position.

of better → Lasty it perfectly has the ability to be fully collapsible. (50)

Systems & Control

Evaluation

Function	The product must be able to sort a range of coins. The product must have a locking system which only opens when a code is entered. Must tell you when each drawer is full.
Client	The product must be aimed at bank tellers who fall in the age group of 20 to 60 years old. The product must not appeal to one gender more than the other.
Safety	The product must not be harmful to people who work in a hurry. The product therefore must not have any sharp edges or pointy parts which could hurt your hands.
Size	Should be a suitable size to fit on a desk and must not be too big to obstruct site for a sitting teller.
Cost	The product costs around \$20 to manufacture, therefore, the product must not cost more than \$60 dollars.
Aesthetics	The product must have a plain, professional look since it has to appeal to bank tellers in a working atmosphere.
Environment	The product must be appropriate for a working environment, more specifically, a bank. The product must also be eco-friendly and its effect on the environment must be as reduced as possible.
Ergonomics	The product must have drawers which can be comfortably pulled by an adult hand.
Finish	The prototype must have a professional, varnished, wooden finish but must have enough space in the casing to be painted with a bank's logo or colours
Scale of Production	The product must be produced in mass, therefore the design must be kept simple enough to do this.

Function	9
Client	10
Safety	8
Size	9
Cost	6
Aesthetics	7
Environment	8
Ergonomics	7
Finish	7
Scale of Production	7

Evaluation against Specifications:

Function: Specifications say that I need compartments for different coins and a locking mechanism which opens the drawers when a right code is inputted. The product has three drawers and a working locking system, based on an acrylic mechanism. Since these two criteria were met I have satisfied the specifications regarding the function of the product.

Client: Specifications say that the product must appeal to bank tellers and must be gender-neutral. The product is painted with the colours of a bank but has a sober casing design and does not have anything which may appeal more to either male or female genders. Because of this, the Client specifications were met.

Safety: Specifications say that the product can't have sharp edges that could harm hasty people. The box is a relatively simple rectangular prism, however, the knobs have been carved as spheres, which is the part more likely to come in contact with the user. I therefore think that the product met the Safety specifications.

Size: Specifications say that the product must fit comfortably on a desk and not obstruct the teller's view. The product is compact and does not measure more than 30cm, which is the approximate distance between a teller's chin and the desk. I have therefore met this specification.

Cost: Specifications say that the product must cost around \$20 to manufacture. However, the manufacturing process, including the scarce components, was around twice times the expected. Even if the specifications' aim was unrealistic, this specification was not met, even though when mass produced the price could be lowered substantially.

Aesthetics: This section of the specifications demand for a sober, professional and visually appealing look. I did manage to get a good-looking sober aesthetic, however, because of the restricted manufacturing time, the look could have been more professional. Overall, this specification was partially met. The comb joint marks in the box make it look a little less professional, hence this could be improved.

Environment: Specifications say that the product must be fit for a working environment and that the impact on the environment must be as reduced as possible. The product is not too flashy and looks well in a banking atmosphere. Even though the materials used were not the most renewable (predominantly MDF and acrylic), the impact on the environment was reduced by reusing other people's acrylic and MDF sheets. I believe that the Environment specifications were met.

Ergonomics: Specifications say that the drawers must be easy and comfortable to pulled. I used the metal engraving machine to CAM the brass drawers, which are rounded in shape and therefore very comfortable. This specification was met successfully.

Finish: Specifications demand a varnished wooden finished and space to paint in a bank's logo. After applying the paint to the casing, a layer of varnished was applied. Because of the plain finish, a lot of space is apt for the painting of a logo. The Finish specifications were therefore met.

Scale of Production: Specifications demand a simple design in order to mass produce. The prototype was obviously not produced in mass, but I believe it has a suitable design for mass-production. This specification was met.

Example 5

A detailed evaluation using the specification.

Systems & Control

Evaluation

Verdict:

As predicted the design idea's table on the previous page, the cost specifications were the least likely to be met. The final cost of the product was almost double that of the specifications, however, once it is mass produced, the cost of the casing's materials will be lowered substantially. However, I do believe that some electronic aspects could be tweaked to lower the final price.

The function specifications (which I consider to be the most important ones) were met perfectly, which makes my product a very successful first prototype.

The aesthetics, which were only partially met in the specifications, would be improved upon in the next versions of the prototype. The comb joint marks are not the most appealing and could go away.

According to my design idea's table, the client's specification would have been met the most. However, I do believe that including more bank branding on the box would make it even more suitable for the target client, even though it did meet this set of specifications.

The finish could also be more crisp, even though it is just a first prototype. I believe it met specifications for this project, even though it still could be much improved. The bank branding and removal of comb joint marks would raise this standards by much.

Finally, the other specifications were met appropriately.

In conclusion, I believe that this first prototype of my product met most of the specifications' criteria thoroughly. I believe that, if produced better, it would suit all of my possible clients' needs, therefore I am happy with the final result. (bearing in mind that this is still the first prototype). Overall, this has been a successful project.

Improvements:

Even though the product was an overall success, I believe several improvements could be made.

The mechanism could be somehow tied to the plate which holds the circuit so that the drawers can't open even a couple of millimetres when the lock is closed.

Lubricating the mechanism with grease would make it work better. I would try to lower the cost of the manufacturing as much as possible by using recycled material, using less costly alternative materials and trying not to use more material than needed in order to come closer to the market price. The product will also be less expensive to produce once it goes into mass production.

I would put more time in making the product look more professional, that is, trying not to leave 1mm gaps between components, trying not to have any scratches in the casing or jagged/rough surfaces and giving it a more glossy appearance overall. Including more vinyl stickers would also be a good idea.

Finally, I would include a lock for the bill compartment to protect its content.

Example 6

Clear points made, very good summary. This evaluation could have benefitted from photographs or sketches to explain the issues more clearly.

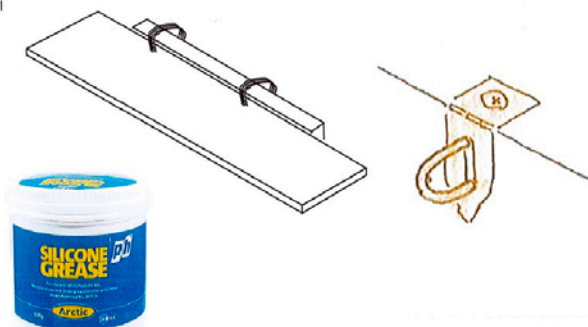

1.6 Use of ICT

Learners are encouraged to make use of the full range of ICT including CAD / CAM, if facilities are available to them. However, they will not be penalised if ICT is not used in their project work. Many learners present parts of their design folders through its use, for example for word processing and the production of formal drawings.

Section 2: Administering the project

2.1 General issues

As the project is expected to be carried out at the end of the course, it is assumed that learners will be familiar with the design process and will have carried out a series of design-and-make projects. Some of their early work will probably have focused on particular aspects of the design process with later projects encompassing all the design-and-make stages.

To allow learners sufficient time to complete their project and take into account the deadlines for the submission of marks, this means that work will probably start at the beginning of the final year of a two-year course, i.e. January / February for those taking the examination in November, and September / October for those taking the examination in June.

It is important that your learners choose projects that can be completed in the time available, stretches them to their full abilities and satisfies the requirements of the assessment criteria. Clear guidance and advice from you is vital.

The project will probably take up most of the classroom time during this period, but this can be complemented with the teaching of the knowledge content to help prepare learners for their written examination paper. There are many different approaches to obtaining this balance and the knowledge content could be covered through design projects. However, you must ensure that all syllabus topics are covered and that your learners have opportunities to practise examination papers.

2.2 Health and safety

The syllabus contains a list of learning objectives for health and safety and this covers all issues linked to the use of tools and equipment in a workshop. You need to make sure that you are familiar with all hazards in your learners' workspace.

Your learners will be working on their projects individually, so it is important that particular care is taken and precautions are in place to protect learners when using dangerous machines, equipment, hazardous materials and heat processes.

You should take particular care and to follow local guidelines when learners are considering the use of mains electricity in their projects.

2.3 Guidance to learners

The question most commonly asked is, 'How much help do I give my learners?' The simple answer to this is that you should be seen as a resource to be used just in the way that a learner might refer to information in a book. Guidance and advice should be given but the learner must carry out the work on their own. There are times when some learners may require extra input and help to move from one stage to the next. Under these circumstances you should acknowledge this help and take account of it in the award of marks for the relevant section of the assessment criteria.

Learners must receive sufficient guidance to give them the opportunity to access all of the marks available. To do this, the evidence they produce will need to meet the syllabus requirements. You need to monitor the progress of your learners on a regular basis so that you are always aware of the stage that each individual learner has reached.

You may require your learners to produce some material for their projects as homework. This is acceptable as long as you are familiar with learners' ability and can be as sure as possible that the work produced is their own. Be cautious of allowing learners to produce much of their 'made product' away from the classroom and school facilities as you may find it difficult to authenticate their work with any degree of certainty.

2.4 Internal assessment (marking by teachers)

The *Cambridge Handbook* provides the deadline for the submission of final project marks for each examination session and this should be adhered to.

You are required to mark the projects of each learner using the project assessment criteria which are contained in the syllabus. Marks for each criterion should be recorded against each learner's name on the Coursework Assessment Summary Form, available from www.cambridgeinternational.org/samples.

The individual marks should be added up and checked by a second person. The total marks should then be transferred to mark sheet MS1 and sent to Cambridge International before the examination series. The transfer of marks should also be checked.

When several teachers are involved in internal assessment of coursework, arrangements must be made within your Centre for all learners to be assessed to a common standard. It is essential that, within each Centre, the marks for each skill assigned within different teaching groups are moderated internally for the whole cohort. The Centre's assessment will then be subject to external moderation.

2.5 External moderation

Coursework Assessment Summary Forms and the moderator copy of the computer-printed mark sheet MS1 must be received by Cambridge International no later than 30 April for the June examination and 31 October for the November examination, together with a sample of the projects undertaken by the learners.

The sample submitted for external moderation should:

- represent the spread of marks across the entire ability range for the cohort, to include the top scoring piece of coursework, some middle range marks and the lowest scoring piece of work
- include a balance of work from learners across all teaching sets and assessors
- include the second copy of the MS1
- contain information on the circumstances in which coursework was completed by learners and about how you undertook internal moderation.

Each sample should:

- include the learners' coursework clearly marked with their name, candidate number, and your Centre name and number
- include the Coursework Assessment Summary Form(s).

On no account should made products be sent for moderation purposes. Design folders must include sufficient photographs of the made product showing an overall view together with detailed views of evidence to support the award of marks for product realisation.

The learners selected for external moderation must be indicated by an asterisk (*) on the Coursework Assessment Summary Form.

You will be able to access all forms and instructions on compiling your sample for external moderation on the Samples database, located on our public website www.cambridgeinternational.org/samples. Enter your Centre number and the relevant syllabus code and the appropriate information will be retrieved from the database for you.

It might be necessary for moderators to call for a further sample of work, beyond the original submission. Full details of this further sample would be addressed to the named Examinations Officer at the Centre.

Centres are asked to retain copies of all Coursework Assessment Summary Forms until the publication of results.

Section 3: Project assessment

3.1 Marking the project

Three projects are available to download from The School Support Hub for you to practise marking.

- Project A: Resistant Materials,
- Project B: Graphic Products
- Project C: Systems and Control.

How to use the mark scheme

On the following pages you will find the project assessment criteria reproduced from the syllabus. Using these criteria, you should attempt to mark the projects. Then, compare your marks with those of the moderator, taking note of the accompanying commentaries.

Each criterion is arranged in distinct marking levels and you will see that if these are read from the bottom to the top, they describe increasingly assured performances. However, in practice, work rarely matches one statement precisely so a balance needs to be made across levels.

You should first mark the work and then make a 'best fit' judgement as to which level to place it in. Very often you may see qualities that fit more than one band, so always use at least two bands and come to a decision between them.

Mark work positively, rewarding what has been achieved rather than penalising learners for any errors they have introduced or for any information they have not included.

If all the criteria in a level fit your judgement, award the highest mark and check the level above, just in case a mark at the bottom of the next level is appropriate.

When you assess the projects for which you are responsible, place them in a rank order and award the marks accordingly, paying special attention to the boundaries of the levels.

The projects available to download are not intended to be examples of prescribed formats or ways in which projects should be produced. They are offered as examples of work that indicate the types of outcome that could justify the marks awarded.

The projects, which were originally in A3 format, should be seen as examples of what is likely to be produced by IGCSE learners.

3.2 Project assessment criteria

Description	Level	Mark
Criterion 1. Identification of a need or opportunity with an analysis leading to a design brief		
Comprehensive investigation and full analysis of the design need, the identification of the intended user(s) and a clear and full design brief.	3	4–5
Relevant investigation with appropriate analysis of the design need, the identification of the intended user(s) and a functional design brief.	2	2–3
Limited investigation with an attempt at some analysis of the design need which results in a simple and unqualified design brief.	1	1
No creditable response.	0	0
Criterion 2. Research into the design brief resulting in a specification		
Full and objective research into the design brief and intended user(s) with thorough analysis of the data/information leading to a detailed and justified specification for the product.	3	7–10
Relevant research into the design brief and intended user(s) with appropriate analysis of the data/information leading to a clear and partly justified specification for the product.	2	4–6
Minimal examination and research into the design brief and intended user(s) resulting in a limited specification for the product.	1	1–3
No creditable response.	0	0
Criterion 3. Generation and exploration of design ideas		
A wide range of imaginative solutions which are conceptually different. Ideas are developed and clarified with reference to the specification. Appropriate drawing techniques are used and are clear and well presented. Detailed and concise annotations explore technical aspects of each idea including consideration of possible materials and constructions. Ideas are evaluated with clear reference to each specification point.	4	16–20
A range of imaginative solutions which are conceptually different. Main ideas are developed and clarified with reference to the specification. Appropriate drawing techniques used with annotations to explore most of the technical aspects including consideration of possible materials and constructions. Ideas are evaluated with some reference to the specification points.	3	11–15
A limited range of solutions. Some ideas are clarified with reference to the specification. Use of appropriate drawing techniques with limited annotations to explore some aspects of each idea. Main ideas are evaluated with some reference to the specification points.	2	6–10
A narrow range of ideas with a tendency to focus on one or two ideas with little or no reference to the specification. Basic sketching skills used. Little or no reference to the evaluation of ideas.	1	1–5
No creditable response	0	0

Description	Level	Mark
Criterion 4. Development of proposed solution		
Comprehensive evidence of modelling and trialling to assist decisions about form, materials, fixings and construction/production methods. Excellent use of appropriate drawing methods which assist the clarification of the technical specification of the item to be manufactured. Evidence of evaluative comments or references to the specification where appropriate.	3	11–15
Adequate evidence of modelling and trialling or sketches with annotations to assist decisions about form, materials, fixings and construction/production methods. Good use of appropriate drawing methods which assist the clarification of the technical specification of the item to be manufactured. Evidence of some evaluative comments or references to the specification.	2	6–10
Some evidence of development towards a single solution. Superficial or limited information on decisions about form, materials, fixings and construction/production methods. Basic use of various drawing methods which assist the clarification of the technical specification of the item to be manufactured. Limited or no reference to the specification.	1	1–5
No creditable response.	0	0
Criterion 5. Planning for production		
High-quality working drawings which include full details for manufacture. Clear and detailed evidence of production planning leading to a logical, clearly communicated, sequence of the stages of manufacture including material lists, fittings and finishes.	3	7–10
Working drawings which include most details for manufacture, e.g. overall layout and major dimensions. Adequate evidence of production planning leading to a logical sequence of the stages of manufacture including most of the details required for material lists, fittings and finishes.	2	4–6
Basic working drawings which may include some details for manufacture, e.g. overall layout and major dimensions. Limited evidence of production planning. Some of the details required for material lists, fittings and finishes.	1	1–5
No creditable response.	0	0

Description	Level	Mark
Criterion 6. Product realisation		
The product will be complete and finished to a very high standard. The overall outcome will be made with precision and accuracy and will function well. The product will fully meet all the requirements of the specification.	6	26–30
The product will be complete and finished to a high standard. The overall outcome will be well made, and will function well, but may have some parts with minor inaccuracies and blemishes. The product will meet most of the requirements of the specification.	5	21–25
The product will be complete and finished to a good standard. The overall outcome will be well made, and will function well, but may contain some inaccuracies and blemishes. The product will meet many of the requirements of the specification.	4	16–20
The product will be mainly complete and finished to a fair standard. The overall outcome will be adequately made, and will partially function, but may contain significant inaccuracies and blemishes. The product will meet some of the requirements of the specification.	3	11–15
The product may not be complete. The overall outcome will be adequately made and will partially function, but may contain significant mistakes, inaccuracies and/or blemishes. The product will meet a few of the requirements of the specification.	2	6–10
The product will not be complete with parts at a poor level of finish. The overall outcome will be basic, and it may not function as intended. The work will contain significant mistakes, inaccuracies and blemishes. The product will meet few or none of the requirements of the specification.	1	1–5
No creditable response	0	0
Criterion 7. Testing and evaluation		
Objective testing and evaluation of the product with systematic reference to its performance, the specification and user. Where appropriate, testing will be carried out in the environment for which the product was intended. Clear identification and analysis of strengths and weaknesses of the product leading to detailed and meaningful conclusions with proposals for further development.	3	7–10
Adequate testing and evaluation of the product with some reference to its performance, the specification and user. Identification of simple strengths and weaknesses of the product leading to some conclusions with proposals for further development.	2	4–6
Little or no evidence of the testing and evaluation of the product with general reference to its performance. Little or no reference to the specification and user. Superficial identification of a limited number of strengths and weaknesses of the product leading to limited proposals for further development.	1	1–3
No creditable response	0	0

Cambridge Assessment International Education
The Triangle Building, Shaftesbury Road, Cambridge, CB2 8EA, United Kingdom
t: +44 1223 553554 f: +44 1223 553558
e: info@cambridgeinternational.org www.cambridgeinternational.org

Copyright © UCLES March 2018